

# MiniMACS6-AMP-4/50/10

Hardware Reference



**CANopen**

**EtherCAT**



maxongroup.com

## TABLE OF CONTENTS

<b>1</b>	<b>ABOUT</b>	<b>5</b>
1.1	About this Document. . . . .	5
1.2	About the Device. . . . .	8
1.3	About the Safety Precautions . . . . .	9
<b>2</b>	<b>SPECIFICATIONS</b>	<b>11</b>
2.1	Technical Data . . . . .	11
2.2	Thermal Data . . . . .	13
2.3	Limitations. . . . .	13
2.4	Dimensional Drawings . . . . .	14
2.5	Standards . . . . .	17
<b>3</b>	<b>SETUP</b>	<b>19</b>
3.1	Generally applicable Rules . . . . .	19
3.2	Mechanical Installation . . . . .	20
3.2.1	Encased Housing Versions . . . . .	20
3.2.2	PCB Versions . . . . .	20
3.3	Cabling . . . . .	23
3.4	Connections . . . . .	25
3.4.1	Power Supply (X8) . . . . .	26
3.4.2	Logic Supply (X1) . . . . .	28
3.4.3	Motor (X10 / X20 / X30 / X40) . . . . .	29
3.4.3.1	DC Motors . . . . .	30
3.4.3.2	DC Twin Motors . . . . .	30
3.4.3.3	Brake Choppers . . . . .	31
3.4.3.4	EC (BLDC or PMSM) Motors . . . . .	31
3.4.3.5	EC (BLDC or PMSM) Twin Motors . . . . .	32

### READ THIS FIRST

***These instructions are intended for qualified technical personnel. Prior commencing with any activities...***

- you must carefully read and understand this manual and
- you must follow the instructions given therein.

***The MiniMACS6-AMP-4/50/10 motion controller is considered as partly completed machinery according to EU Directive 2006/42/EC, Article 2, Clause (g) and is intended to be incorporated into or assembled with other machinery or other partly completed machinery or equipment.***

***Therefore, you must not put the device into service,...***

- unless you have made completely sure that the other machinery fully complies with the EU directive's requirements!
- unless the other machinery fulfills all relevant health and safety aspects!
- unless all respective interfaces have been established and fulfill the herein stated requirements!

3.4.3.6	Stepper Motors	32
3.4.3.7	Motor Combinations	33
3.4.3.8	Limitation of PWM Duty Cycle	35
3.4.4	Hall Sensor (X11 / X21 / X31 / X41)	36
3.4.5	Encoder (X12 / X22 / X32 / X42)	38
3.4.5.1	Digital Incremental Master Encoder	38
3.4.5.2	Digital Incremental Encoder	40
3.4.5.3	Analog Incremental Encoder SinCos	44
3.4.5.4	SSI Absolute Encoder	46
3.5.1	Fields	48
3.5.2	Filter calculation	49
3.5.3	Digital Inputs (X5 / X6)	50
3.5.4	Digital Outputs (X7)	52
3.5.5	STO	53
3.5.6	CAN 1 (X2 / X3) & CAN 2 (X4)	54
3.5.7	USB 1 (X61)	56
3.5.8	USB 2 (X60)	57
3.5.9	NET OUT (X50) & NET IN (X51)	58
3.5.9.1	EtherCAT	59
3.5.9.2	Ethernet	59
3.6	DIP Switch Configuration (SW1)	60
3.6.1	ID (Node-ID / CAN ID / DEV ID)	61
3.6.2	CAN Bus Termination	62
3.7	Status Indicators	63
<b>4</b>	<b>WIRING</b>	<b>65</b>
4.1	Possible Combinations to connect a Motor	66
4.2	Main Wiring Diagram	68
4.3	Excerpts	69
	<b>LIST OF FIGURES</b>	<b>73</b>
	<b>LIST OF TABLES</b>	<b>75</b>
	<b>INDEX</b>	<b>77</b>



# 1 ABOUT

## 1.1 About this Document

### 1.1.1 Intended Purpose

Use the document to...

- stay safe,
- be fast,
- end up with set up and ready-to-go equipment.

The purpose of the present document is to familiarize you with the MiniMACS6-AMP-4/50/10 motion controller. It will highlight the tasks for safe and adequate installation and/or commissioning. Follow the described instructions ...

- to avoid dangerous situations,
- to keep installation and/or commissioning time at a minimum,
- to increase reliability and service life of the described equipment.

The present document is part of a documentation set and contains performance data and specifications, information on fulfilled standards, details on connections and pin assignment, and wiring examples. The below overview shows the documentation hierarchy and the interrelationship of its individual parts:

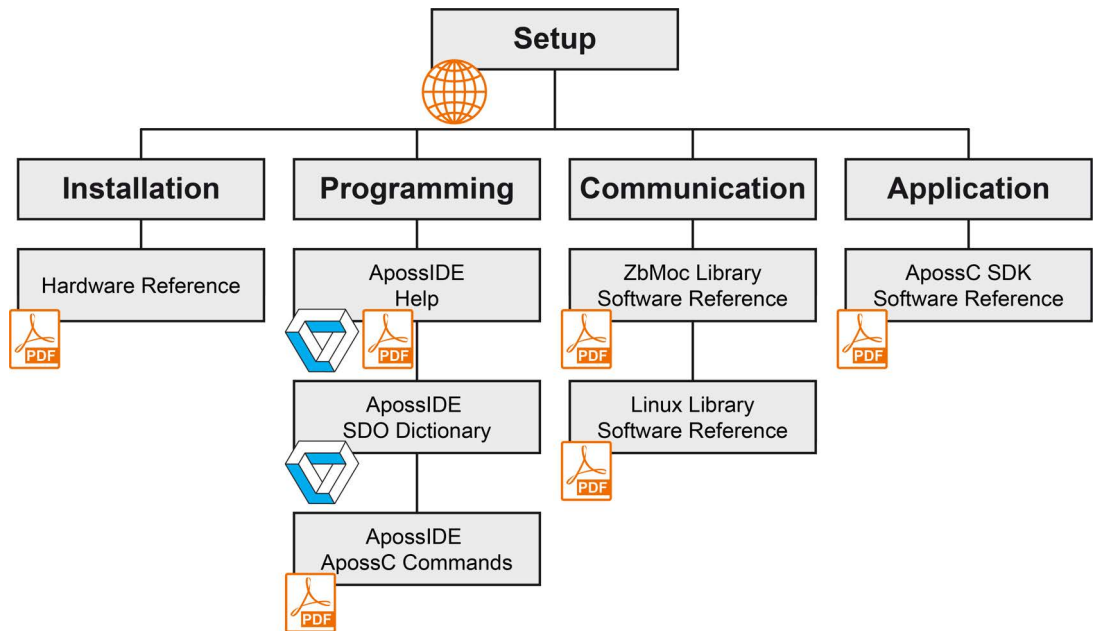

Figure 1-1 Documentation structure

### 1.1.2 Target Audience

The present document is intended for trained and skilled personnel. It conveys information on how to understand and fulfill the respective work and duties.

### 1.1.3 How to use

Throughout the document, the following notations and codes will be used.

Notation	Meaning
(n)	refers to an item (such as part numbers, list items, etc.)
→	denotes “see”, “see also”, “take note of” or “go to”

Table 1-1 Notation used

### 1.1.4 Symbols & Signs

In the course of the present document, the following symbols and signs will be used.







Type	Symbol	Meaning	
Safety alert	 (typical)	DANGER	Indicates an <b>imminent hazardous situation</b> . If not avoided, it <b>will result in death or serious injury</b> .
		WARNING	Indicates a <b>potential hazardous situation</b> . If not avoided, it <b>can result in death or serious injury</b> .
		CAUTION	Indicates a <b>probable hazardous situation</b> or calls the attention to unsafe practices. If not avoided, it <b>may result in injury</b> .
Prohibited action	 (typical)	Indicates a dangerous action. Hence, <b>you must not!</b>	
Mandatory action	 (typical)	Indicates a mandatory action. Hence, <b>you must!</b>	
Information		Requirement / Note / Remark	Indicates an activity you must perform prior continuing, or gives information on a particular item you need to observe.
		Best practice	Indicates an advice or recommendation on the easiest and best way to further proceed.
		Material Damage	Indicates information particular to possible damage of the equipment.

Table 1-2 Symbols and signs

### 1.1.5 Trademarks and Brand Names

For easier legibility, registered brand names are listed below and will not be further tagged with their respective trademark. It must be understood that the brands (the list below is not necessarily concluding) are protected by copyright and/or other intellectual property rights even if their legal trademarks are omitted in the later course of this document.

Brand Name	Trademark Owner
Adobe® Reader®	© Adobe Systems Incorporated, USA-San Jose, CA
APOSS®	© zub machine control AG, CH-Rothenburg
CANopen® CiA®	© CiA CAN in Automation e.V, DE-Nuremberg
CLIK-Mate™ Micro-Fit™ Mini-Fit Jr.™ Mega-Fit®	© Molex, USA-Lisle, IL
EnDat	© DR. JOHANNES HEIDENHAIN GmbH, DE-Traunreut
EtherCAT®	© EtherCAT Technology Group, DE-Nuremberg, licensed by Beckhoff Automation GmbH, DE-Verl
TwinCAT®	© Beckhoff Automation GmbH, DE-Verl
Windows®	© Microsoft Corporation, USA-Redmond, WA

Table 1-3 Brand names and trademark owners

### 1.1.6 Copyright

© 2023 maxon. All rights reserved. Any use, in particular reproduction, editing, translation and copying without prior written approval is not permitted (contact: maxon international ltd., Brünigstrasse 220, CH-6072 Sachseln, +41 41 666 15 00, www.maxongroup.com). Infringements will be prosecuted under civil and criminal law. The mentioned trademarks belong to their respective owner and are protected under trademark laws. Subject to change without prior notice.

mzub | MiniMACS6-AMP-4/50/10 Hardware Reference | Edition 2023-05 | DocID rel11643

## 1.2 About the Device

*Capabilities of the device, included features, and supported motors.*

The MiniMACS6-AMP-4/50/10 combines a cost-efficient, programmable motion control unit with high power amplifiers in a compact housing. Each of its internal amplifiers offers 540 Watts continuous and 1620 Watts peak for direct control of powerful drives.

The MiniMACS6-AMP-4/50/10 is the economic solution to move up to six brushed DC motors, up to four brushless EC (BLDC or PMSM) motors, or three stepper motors in a highly dynamic and most accurate way. Position feedback or master signals are processed by encoder inputs for direct connection of incremental encoders and hall sensors. Optionally, Sin/Cos or SSI encoders can be connected. A variety of digital inputs and outputs process sensor signals and command actuators. The number of I/Os can easily be extended with CANopen I/O modules.

Bus interfaces, such as CANopen and USB, are already integrated and allow communication with computers or other devices for commissioning, firmware updates, and programming. Optionally, the controller can be extended with other industrial Ethernet interfaces, such as EtherCAT, etc. The very efficient, yet easy-to-use programming language combined with outstandingly powerful motion control commands are the key for standalone control of simple machines and devices without the need of using a PC or PLC at all.

The controller features optionally available, factory-mounted extension slots. They host respective extension cards and thereby expand the controller's comprehensive motion control functionality even further.

- **EXT1** provides connectivity for an optionally available communication extension card. With the «MiniMACS6-IF1» option card, the controller serves as slave in an EtherCAT network, provides access for EtherCAT master control (such as Beckhoff TwinCAT), and offers real-time operation in an Ethernet master/slave network with integrated Ethernet switch.
- **EXT2** provides connectivity for advanced signal extension cards, such as for additional absolute sensors or customized signal extensions. Using the respective optionally available «MiniMACS6-AMP-4/50/10 Extension Cards», additional functions can be directly accessed via the connector.

The MiniMACS6-AMP-4/50/10 is available in the following variants:

Designation	P/N	Design	Extension	
			EXT1	EXT2
MiniMACS6-AMP-4/50/10	001755	encased housing	—	—
MiniMACS6-AMP-4/50/10-IF1 EtherCAT	001757	encased housing	IF1	—
MiniMACS6-AMP-4/50/10-IF1 Ethernet	001784	encased housing	IF1	—
MiniMACS6-AMP-4/50/10-OEM	001756	open design (without housing)	—	—

Table 1-4 Available variants



Find the latest edition of documentation and software here:  
→ <https://www.maxongroup.ch/maxon/view/content/motion-controller>



Find information on zub's «ApossIDE®» here:  
→ <https://www.maxongroup.ch/maxon/view/product/control/Motion-Control/001755>  
→ [https://www.maxongroup.ch/medias/sys\\_master/root/9063217823774/ApossC-SDK.zip](https://www.maxongroup.ch/medias/sys_master/root/9063217823774/ApossC-SDK.zip)  
→ [https://www.maxongroup.ch/medias/sys\\_master/root/9063217889310/ApossIDE.zip](https://www.maxongroup.ch/medias/sys_master/root/9063217889310/ApossIDE.zip)



### 1.3 About the Safety Precautions

Keep in mind:  
Safety first!  
Always!

- Make sure that you have read and understood the note “READ THIS FIRST” on page A-2!
- Do not engage with any work unless you possess the stated skills (→chapter “1.1.2 Target Audience” on page 1-6)!
- Refer to →chapter “1.1.4 Symbols & Signs” on page 1-6 to understand the subsequently used indicators!
- You must observe any regulation applicable in the country and/or at the site of implementation with regard to health and safety/accident prevention and/or environmental protection!



#### DANGER

##### **High voltage and/or electrical shock**

##### **Touching live wires causes death or serious injuries!**

- Consider any power cable as connected to live power, unless having proven the opposite!
- Make sure that neither end of cable is connected to live power!
- Make sure that power source cannot be engaged while work is in process!
- Obey lock-out/tag-out procedures!
- Make sure to securely lock any power engaging equipment against unintentional engagement and tag it with your name!



#### Requirements

- Make sure that all associated devices and components are installed according to local regulations.
- Be aware that, by principle, an electronic apparatus cannot be considered fail-safe. Therefore, you must make sure that any machine/apparatus has been fitted with independent monitoring and safety equipment. If the machine/apparatus should break down, if it is operated incorrectly, if the control unit breaks down or if the cables break or get disconnected, etc., the complete drive system must return – and be kept – in a safe operating mode.
- Be aware that you are not entitled to perform any repair on components supplied by maxon.



#### Electrostatic sensitive device (ESD)

- Wear working cloth and use equipment in compliance with ESD protective measures.
- Handle device with extra care.

••page intentionally left blank••

## 2 SPECIFICATIONS

### 2.1 Technical Data

MiniMACS6-AMP-4/50/10 (001755) MiniMACS6-AMP-4/50/10-IF1 EtherCAT (001757) MiniMACS6-AMP-4/50/10-IF1 Ethernet (001784) MiniMACS6-AMP-4/50/10 OEM (001756)			
<b>Memory</b>	Workspace and program memory	768 kB for application, data, and oscilloscope	
<b>Electrical Rating</b>	Nominal power supply voltage $+V_{CC}$ [a]	10...60 VDC	
	Absolute power supply voltage $+V_{min} / +V_{max}$ [a]	9 VDC / 66 VDC	
	Nominal logic supply voltage $+V_C$ [a]	24 VDC	
	Absolute logic supply voltage $+V_{min} / +V_{max}$	18 VDC / 30 VDC	
	Output voltage (max.) [b]	$0.88 * V_{CC}$	
	Output current $I_{cont} / I_{max}$	10 A / 30 A	
	Output twin current [c] $I_{cont} / I_{max}$	18 A / 54 A	
	Pulse Width Modulation frequency	48 kHz (20.8 $\mu$ s)	
	Sampling rate PI current controller	24 kHz (41.7 $\mu$ s)	
	Sampling rate PI speed controller	8 kHz (125 $\mu$ s)	
	Sampling rate PID positioning controller	1 kHz (1 ms)	
	Sampling rate analog input	1 kHz (1 ms)	
	Max. efficiency	98%	
	Max. speed	DC motor	limited by max. permissible speed (motor) and max. output voltage (controller)
		EC motor (block)	100'000 rpm (1 pole pair)
EC motor (sinus)		100'000 rpm (1 pole pair)	
Built-in motor choke [h]		none	

Continued on next page.

MiniMACS6-AMP-4/50/10 (001755) MiniMACS6-AMP-4/50/10-IF1 EtherCAT (001757) MiniMACS6-AMP-4/50/10-IF1 Ethernet (001784) MiniMACS6-AMP-4/50/10 OEM (001756)			
<b>Inputs &amp; Outputs</b>	Digital Input 1...16 (general purpose) [d]	<ul style="list-style-type: none"> <li>• Low &lt;5 VDC, high &gt;18 VDC</li> <li>• Digital Input 1...4 with latch function</li> <li>• Digital Input 9...12 usable as 0...10 V analog input</li> </ul>	
	Digital Output 1...8 (general purpose)	24 VDC / $I_L \leq 100$ mA	
	Analog Input 1...4 (@DigIN9...12)	Resolution 12-bit, 0...+10 V, 1 kHz	
	Digital Hall sensor signals H1, H2, H3	+2.0...+24 VDC (internal pull-up)	
	Sensor signals (choice between multiple functions) <ul style="list-style-type: none"> <li>• Digital incremental encoder</li> <li>• Analog incremental encoder SinCos</li> <li>• SSI absolute encoder</li> </ul>	3-channel, EIA RS422 3-channel, resolution 12-bit, $\pm 1.2$ V, differential configurable, EIA RS422	
	Digital incremental master encoder	2-channel output, EIA RS422	
<b>Voltage Outputs</b>	Sensor supply voltage $V_{\text{Sensor}}$	+5 VDC / $I_L \leq 1$ A	
	Digital I/O output voltage $V_{\text{IO}}$	+24 VDC; $I_L \leq 1$ A	
<b>Motor Connections</b>	DC motor 1...6	+ Motor, - Motor	
	EC (BLDC or PMSM) motor 1...4	Motor windings U, V, W	
	Stepper motor 1...3	+A, -A, +B, -B	
	Brake chopper [e]	+ Motor, - Motor	
<b>Interfaces</b>	USB 2.0	High Speed	
	CAN 1	max. 1 Mbit/s, CANopen Master or Slave	
	CAN 2	max. 1 Mbit/s, CANopen Master	
	EtherCAT [f]	Full duplex (100 Mbit/s) as to IEEE 802.3 100 Base T	
	Ethernet [f]	Full duplex (100 Mbit/s) as to IEEE 802.3 100 Base T, including integrated Ethernet switch	
<b>Status Indicators</b>	Power	green LED	Logic supply present, power supply present, firmware running
	State	yellow LED	Application running (default)
	Error	red LED	Error
	RUN [f]	green LED	Operation
	ERR [f]	red LED	Error
	NET PORT [f]	green LED	Link activity
<b>Physical</b>	Weight	approx. 500 g	
	Dimensions (L x W x H)	141 x 110 x 30 mm	
	Mounting	mounting holes for M4 screws	

Continued on next page.

MiniMACS6-AMP-4/50/10 (001755) MiniMACS6-AMP-4/50/10-IF1 EtherCAT (001757) MiniMACS6-AMP-4/50/10-IF1 Ethernet (001784) MiniMACS6-AMP-4/50/10 OEM (001756)			
<b>Environment</b>	Temperature	Operation [g]	-30...+70 °C
		Storage	-30...+85 °C
	Humidity	5...90 % (condensation not permitted)	

- [a] The power supply must be electrically (galvanically) isolated from the logic supply.
- [b] Depends on motor type. → check table 3-26 “Maximum duty cycle levels for different motor types and axis numbers” on page 3-35
- [c] In order to drive higher output currents, each motor phase gets driven by two half bridges in parallel.
- [d] Use of the SinCos function of ENC3 or ENC4 deactivates the analog inputs.
- [e] Brake choppers limit the excess voltage being generated during deceleration by switching the braking energy to a resistor, which converts electrical energy to heat. Therefore, a resistor and a choke must be connected between “+ Motor” and “- Motor”.
- [f] Available with optional MiniMACS6 IF1 option card.
- [g] If the PCB temperature exceeds +80 °C, the power stage will be switched off.
- [h] An external choke is recommended to reduce the current ripple, for loads with a small induction.

Table 2-5 Technical data

## 2.2 Thermal Data

The MiniMACS6-AMP-4/50/10 features temperature monitoring of its power stage. The actual temperature can be retrieved using zub’s «APOSS» user interface.

The main logic is as follows:

- a) Upon exceeding 80 °C, the power stage will be switched off in order to protect the electronics.
- b) After falling below 80 °C, the motion control functionality will resume.

## 2.3 Limitations

Protection functionality	Switch-off threshold	Recovery threshold
Power supply under voltage	9 V	9 V
Logic supply under voltage	17 V (disable load)	[i]
Power supply overvoltage	66 V	66 V
Over current	32 A	—
Thermal overload	80 °C	80 °C

- [i] After a logic supply under voltage detection, the MiniMACS6-AMP-4/50/10 must be switched off/on prior use.

Table 2-6 Limitations

2.4 Dimensional Drawings

2.4.1 MiniMACS6-AMP-4/50/10 (001755)

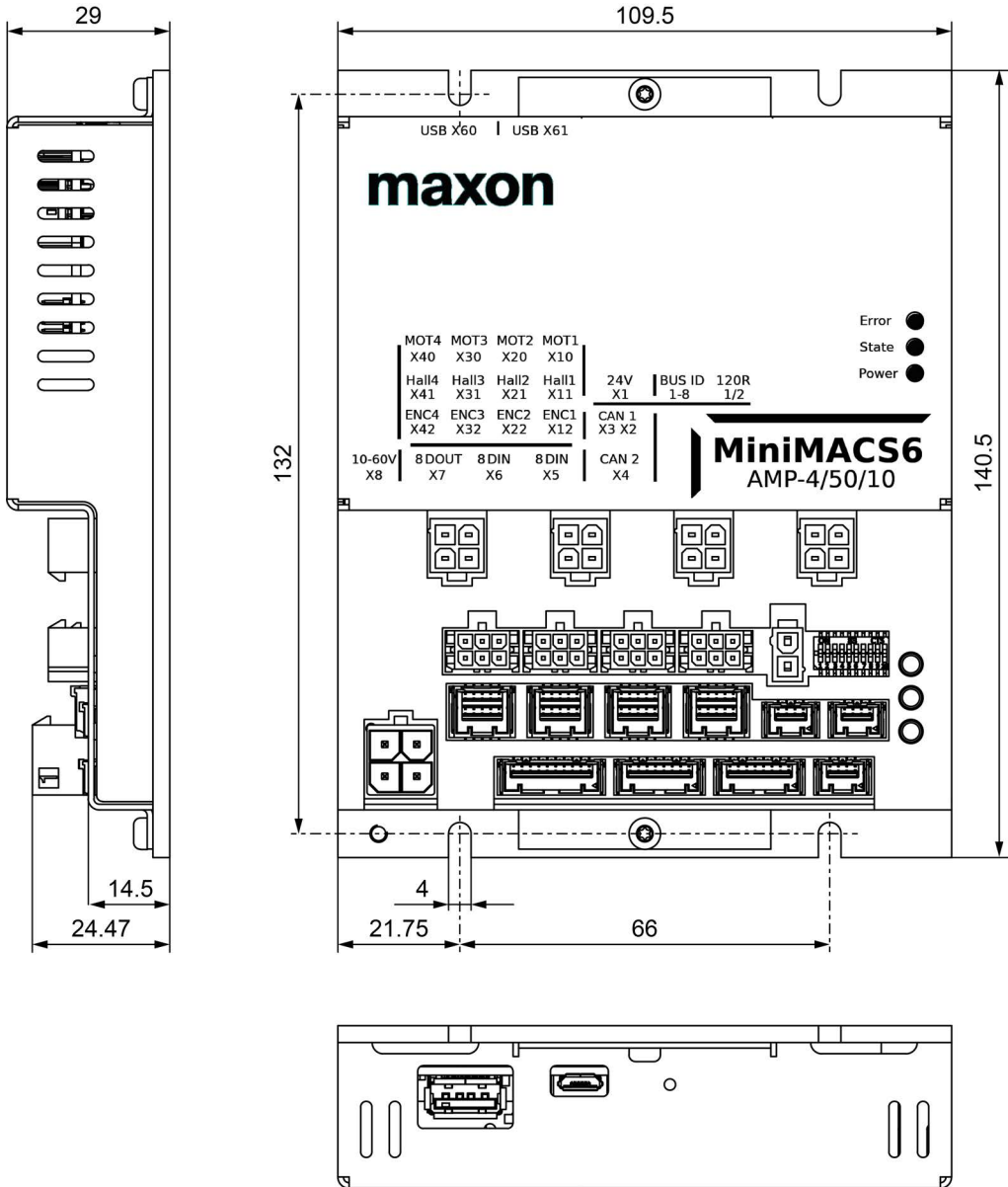

Figure 2-2 MiniMACS6-AMP-4/50/10 (001755) – Dimensional drawing [mm]

**2.4.2 MiniMACS6-AMP-4/50/10-IF1 EtherCAT (001757)**  
**MiniMACS6-AMP-4/50/10-IF1 Ethernet (001784)**

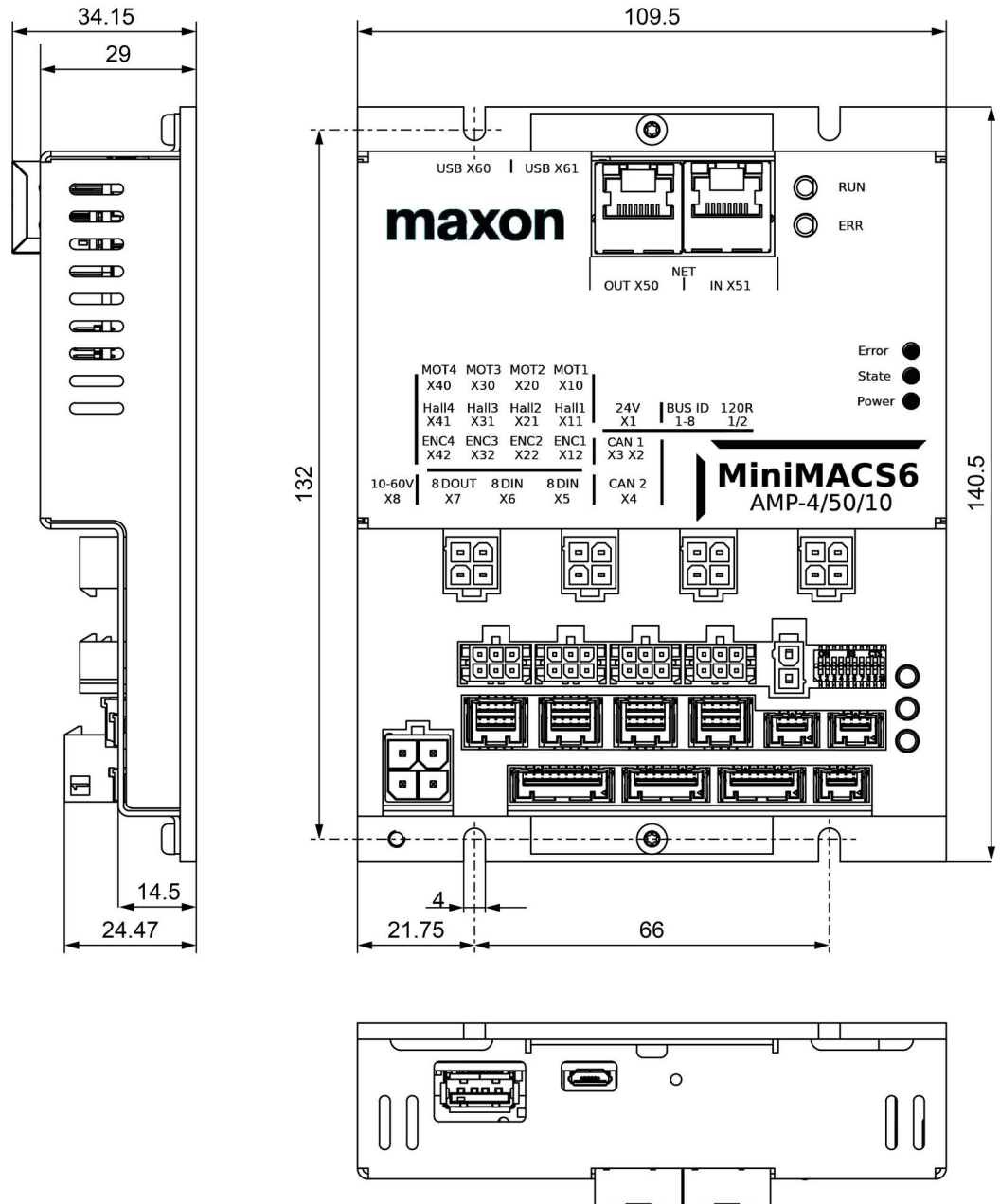

Figure 2-3 MiniMACS6-AMP-4/50/10-IF1 EtherCAT (001757) and MiniMACS6-AMP-4/50/10-IF1 Ethernet (001784) – Dimensional drawing [mm]

2.4.3 MiniMACS6-AMP-4/50/10-OEM (001756)

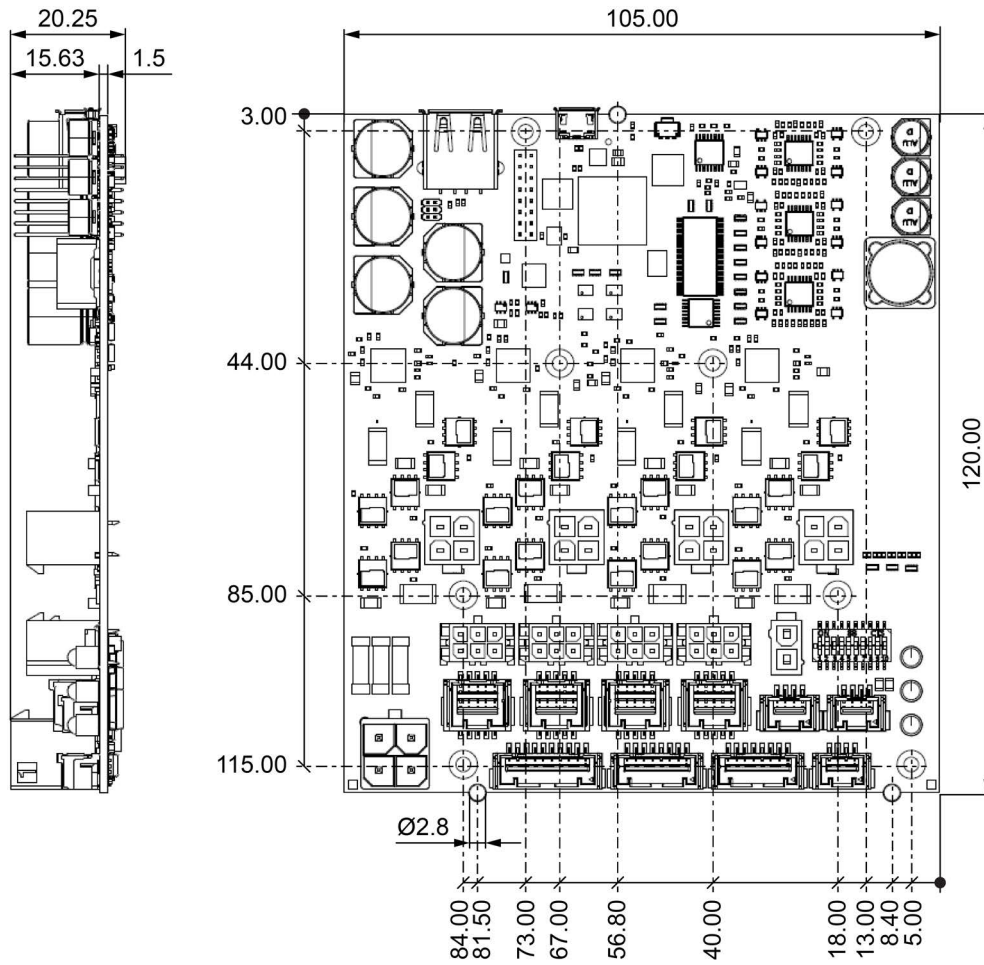

Figure 2-4 MiniMACS6-AMP-4/50/10-OEM (001756) – Dimensional drawing [mm]



## 2.5 Standards

The described device has been successfully tested for compliance with the below listed standards. In practical terms, only the complete system (the fully operational equipment comprising all individual components, such as motor, servo controller, power supply unit, EMC filter, cabling etc.) can undergo an EMC test to ensure interference-free operation.



### Important Notice

*The device's compliance with the mentioned standards does not imply its compliance within the final, ready to operate setup. In order to achieve compliance of your operational system, you must perform EMC testing of the involved equipment as a whole.*

Electromagnetic Compatibility (under development)		
Generic	IEC/EN 61000-6-2	Immunity for industrial environments
	IEC/EN 61000-6-3	Emission standard for residential, commercial and light-industrial environments
Applied	IEC/EN 55022 (CISPR22)	Radio disturbance characteristics / radio interference
	IEC/EN 61000-4-2	Electrostatic discharge immunity test 8kV/6kV
	IEC/EN 61000-4-3	Radiated, radio-frequency, electromagnetic field immunity test >10 V/m
	IEC/EN 61000-4-4	Electrical fast transient/burst immunity test ±2 kV
	IEC/EN 61000-4-6	Immunity to conducted disturbances, induced by radio-frequency fields 10 Vrms
Reliability	MIL-HDBK-217F	Reliability prediction of electronic equipment Environment: Ground, benign (GB) Ambient temperature: 298 K (25 °C) Component stress: Nominal power Mean Time Between Failures (MTBF) <ul style="list-style-type: none"> <li>• MiniMACS6-AMP-4/50/10: 173'551 hours</li> <li>• MiniMACS6-AMP-4/50/10-IF1-ECAT: 154'298 hours</li> <li>• MiniMACS6-AMP-4/50/10-IF1-Ethernet: 154'298 hours</li> </ul>

Table 2-7 Standards

••page intentionally left blank••

### 3 SETUP

#### IMPORTANT NOTICE: PREREQUISITES FOR PERMISSION TO COMMENCE INSTALLATION

The MiniMACS6-AMP-4/50/10 motion controller is considered as partly completed machinery according to EU Directive 2006/42/EC, Article 2, Clause (g) and **is intended to be incorporated into or assembled with other machinery or other partly completed machinery or equipment.**



#### WARNING

##### **Risk of injury**

**Operating the device without the full compliance of the surrounding system with the EU Directive 2006/42/EC may cause serious injuries!**

- Do not operate the device, unless you have made completely sure that the other machinery fully complies with the EU directive's requirements!
- Do not operate the device, unless the other machinery fulfills all relevant health and safety aspects!
- Do not operate the device, unless all respective interfaces have been established and fulfill the requirements stated in this document!

#### 3.1 Generally applicable Rules



##### **Mandatory criteria for connection of motors**

Motors can be configured in numerous constellations, provided that certain criteria are being met. If you decide on combining different types of motors, check on the mandatory criteria, first. For details see →chapter "3.4.3.7 Motor Combinations" on page 3-33.



##### **Maximal permitted supply voltage at the power supply input (X8)**

- The power supply must be electrically (galvanically) isolated from the logic supply.
- Make sure that the supply power is between 10...60 VDC.
- Supply voltages above 66 VDC or wrong polarity will destroy the unit.
- Note that the necessary output current is depending on the load torque. Yet, the output current limits are as follows:
  - continuous max. 10 A
  - short-time (acceleration) max. 30 A



##### **Maximal permitted supply voltage at the logic supply input (X1)**

- Make sure that the supply power is 24 VDC.
- Supply voltages above 30 VDC or wrong polarity will destroy the unit.
- Note that the necessary output current is depending on the load (connected sensors and driven outputs). With no external load connected, the minimum supply current is 200 mA.



##### **Hot plugging the USB interface may cause hardware damage**

If the USB interface is being hot-plugged (connecting while the power supply is on), the possibly high potential differences of the two power supplies of controller and PC/Notebook can lead to damaged hardware.

- Avoid potential differences between the power supply of controller and PC/Notebook or, if possible, balance them.
- Insert the USB connector first, then switch on the power supply of the controller.

Continued on next page.



---

**Hot plugging/hot swapping the extension slots may cause hardware damage**

Switch off the controller's power supply before removing or inserting an extension card.

---



---

**Simplified notation**

For ease of reading, in some cases the generic use of connectors is indicated as follows:

- «Xn0» will be used for connectors X10, X20, X30, and X40.
  - «Xn1» will be used for connectors X11, X21, X31, and X41.
  - «Xn2» will be used for connectors X12, X22, X32, and X42.
- 

## 3.2 Mechanical Installation

Depending on the type of controller you are using you will need to perform the following tasks. Note that the items mentioned are not included in the scope of delivery.

### 3.2.1 Encased Housing Versions

- 1) Mount the controller using 4ea M4 screws. For the drilling pattern...
  - for (001755) see →Figure 2-2 on page 2-14,
  - for (001757) and (001784) see →Figure 2-3 on page 2-15.
- 2) Connect the controller to earth using the M3 thread at the controller's housing base.

### 3.2.2 PCB Versions

Due to the controller's open design you will first need to consider the following:

#### Earthing

You must insure that all eight (8ea) mounting holes (→Figure 3-5; green and yellow marked) are fully connected to earth.

#### Cooling

You must ensure that the temperature of the PCB will remain below 80 °C during operation. Note that PCB temperatures exceeding 80 °C will disable all motor drives. Also note that the higher the motor currents, the more efficient the cooling design and thus heat dissipation capabilities must be.

A good way to efficiently dissipate the heat from the controller is to attach a heat sink—which composes a cooling plate equipped with an electrical insulation. Check below →Table 3-8 for quantities and types as well as →Figure 3-6 and →Figure 3-7 for dimensions of the items needed to build a well capable heat sink.



---

**Wrong heat sink design may destroy the unit**

- The silicone pad's break-down voltage must be at least 1 kV.
  - The silicone pad must protrude the cooling plate on the entire circumference by 1 mm.
  - The dimensions of the silicone pad and cooling plate must be as to →Figure 3-6 and →Figure 3-7.
- 

- 1) Prepare the heat sink comprising silicone pad and cooling plate as to the above descriptions.
- 2) Drill 8ea holes/threads as to the actual design of your application's structure. For the drilling pattern see →Figure 3-5.
- 3) Mount the heat sink (first silicone pad, then cooling plate) to the reverse side of the controller.
- 4) Mount both the controller together with the heat sink to the application's structure using 8ea M2.5 screws.
- 5) Make sure that the controller's heat sink and the application's structure form a tight, gap-free fit.
- 6) Make sure that all eight mounting points are connected to earth.

Continued on next page.

Required parts for PCB versions (not included in delivery)		
Mounting screws	4ea M2.5 screws and 4ea M2.5 screws/nuts that fit the spacers (for drilling pattern see →Figure 3-5)	
Spacers	4ea M2.5 L=4.3 mm for example by Ettinger (05.12.045)	Brass, nickel-plated
Silicone pad	1ea 96.7x52x0.3 mm (→Figure 3-6) for example by Fischer Elektronik (WST85)	Silicone
Cooling plate	1ea 94.7x50x4 mm (→Figure 3-7)	Aluminum

Table 3-8 Required parts for mechanical installation of PCB versions

**DRILLING PATTERN**

- Green marked holes serve both for mounting the heat sink and for fixation of the controller and heat sink to the application’s structure.
- Yellow marked holes serve for additional fixation to the application’s structure using spacers.

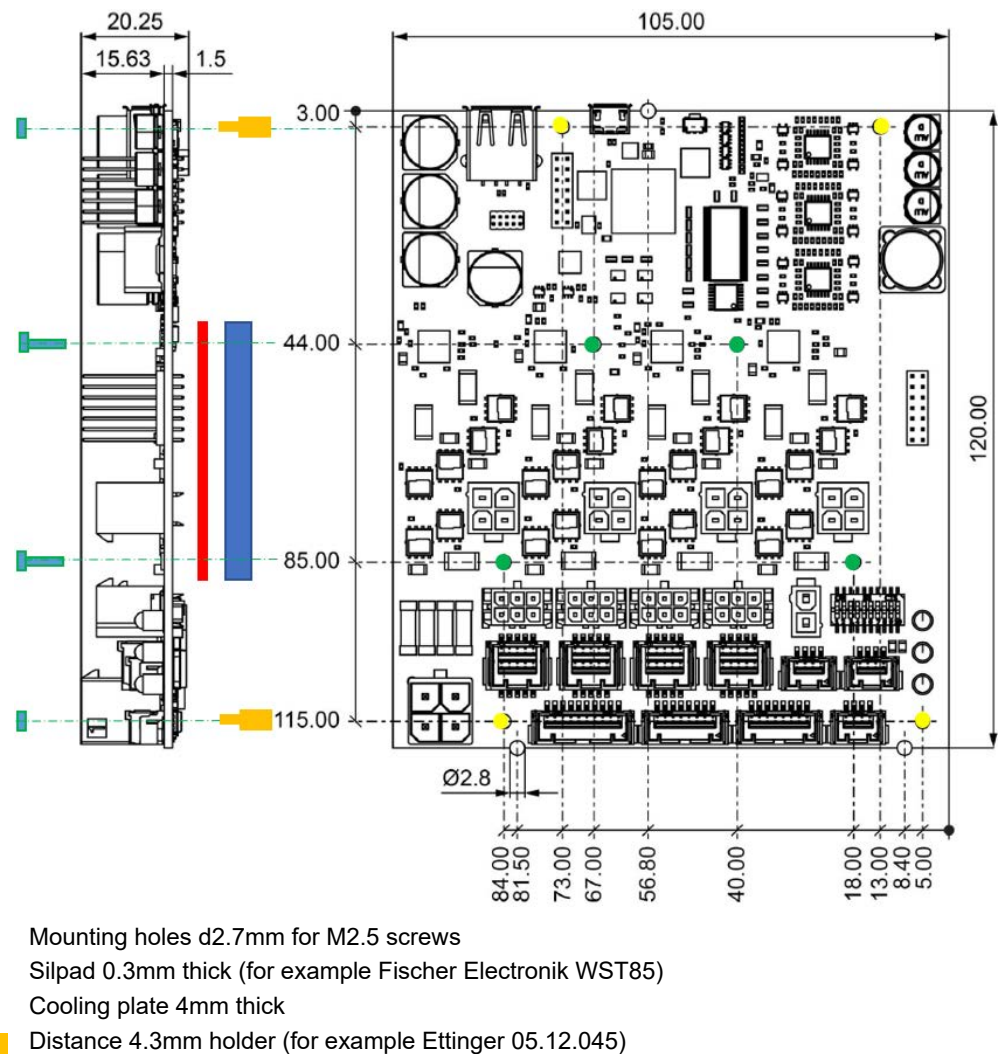

Figure 3-5 Mounting holes

**SILICONE PAD**

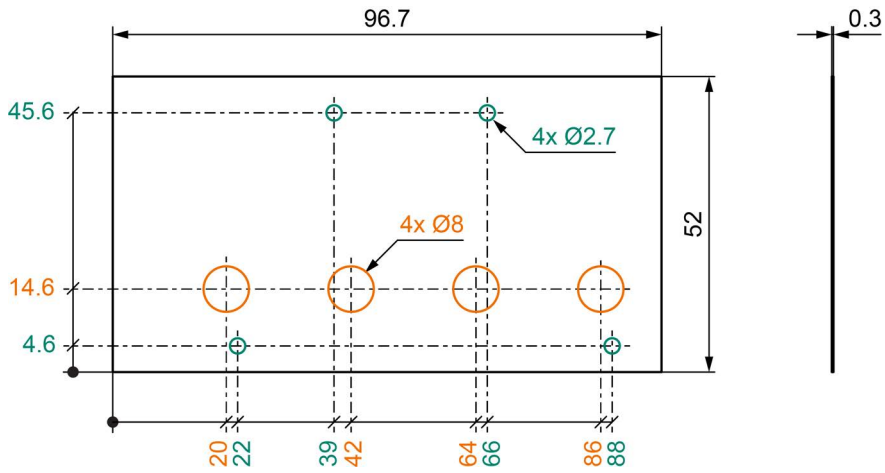

Figure 3-6 Silicone pad

**HEAT SINK**

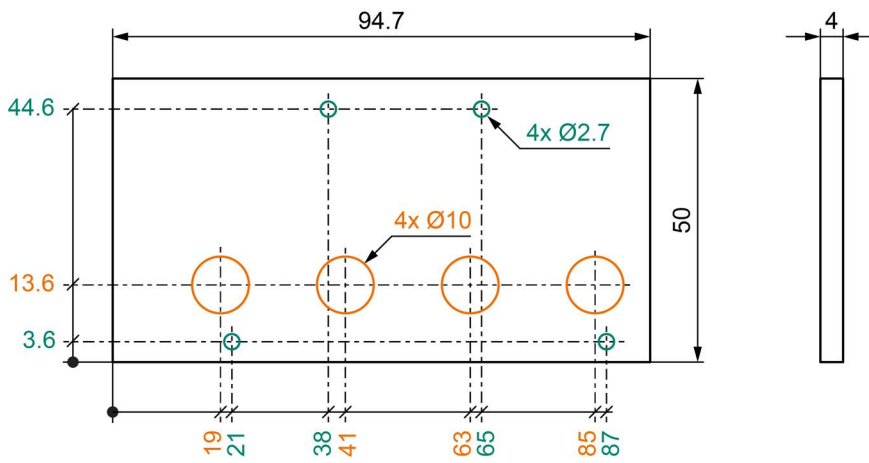

Figure 3-7 Cooling plate

### 3.3 Cabling

#### PLUG&PLAY

Take advantage of maxon's prefab cable assemblies. They come as ready-to-use parts and will help to reduce commissioning time to a minimum.

- a) Check the following table and find the part number of the cable assembly that matches the setup you will be using.
- b) Follow the cross-reference to get the cable's pin assignment.

Connector	Prefab Cable Assembly		
	Designation	Part Number	→Page
X1	Power Cable	275829	3-28
X2 / X3 / X4	CAN-COM Cable	520857	3-54
	CAN-CAN Cable	520858	3-55
X5 / X6	Signal Cable 8core	520853	3-50
X7	Signal Cable 10core	696837	3-52
X8	Power Cable High Current	699485	3-26
X10 / X20 / X30 / X40	Motor Cable	275851	3-29
X11 / X21 / X31 / X41	Hall Sensor Cable	275878	3-36
X12 / X22 / X32 / X42	Sensor Cable 5x2core	520852	3-39
X50 / X51	Ethernet Cable	422827	3-59
X61	USB 1 Type A - micro B Cable	403968	3-56

Table 3-9 Prefab maxon cables

#### MAKE&BAKE YOUR OWN

If you decide not to employ maxon's prefab cable assemblies, you might wish to use the prepackaged kit that contains all connectors required to make up your own cabling.

MiniMACS6 AMP-4/50/10 Connector Set (001772)		
Connector	Specification	Quantity
<b>Connectors</b>		
X1	Molex Mini-Fit Jr., 2 poles (39-01-2020)	1
X2 / X3 / X4	Molex CLIK-Mate, single row, 4 poles (502578-0400)	3
X5	Molex CLIK-Mate, single row, 10 poles (502578-1000)	1
X6 / X7	Molex CLIK-Mate, single row, 8 poles (502578-0800)	2
X8	Molex Mega-Fit, 4 poles (171692-0104)	1
X10 / X20 / X30 / X40	Molex Mini-Fit Jr., 4 poles (39-01-2040)	4
X11 / X21 / X31 / X41	Molex Micro-Fit 3.0, 6 poles (430-25-0600)	4
X12 / X22 / X32 / X42	Molex CLIK-Mate, dual row, 10 poles (503149-1000)	4

Continued on next page.

MiniMACS6 AMP-4/50/10 Connector Set (001772)		
Connector	Specification	Quantity
<b>Crimp Terminals</b>		
X1 / X10 / X20 / X30 / X40	Molex Mini-Fit Jr. female crimp terminal (45750-1111)	18
X11 / X21 / X31 / X41	Molex Micro-Fit 3.0 female crimp terminal (43030-0010)	24
X2...X7 / X12 / X22 / X32 / X42	Molex CLIK-Mate crimp terminal (502579-0100)	78
X8	Molex Mega-Fit, female crimp terminal (172063-0311)	4

Table 3-10 MiniMACS6 AMP-4/50/10 Connector Set – Content

**TOOLS**

Tool	Manufacturer	Part Number
Hand crimper for CLIK-Mate crimp terminals	Molex	63819-4600
Hand crimper for Micro-Fit 3.0 crimp terminals	Molex	63819-0000
Hand crimper for Mega-Fit crimp terminals	Molex	63825-7100
Hand crimper for Mini-Fit crimp terminals	Molex	63819-0900

Table 3-11 Recommended tools



### 3.4 Connections

The actual connection will depend on the overall configuration of your drive system and the type and number of motors you will be using. For each connector you will find detailed information on the pin assignment, available accessories and prefab cable assemblies, circuitry, and requirements that must be met, if any.



#### How to read pin assignment tables

In the later course of the document you will find tables containing information on the hardware connectors, their wired signals and assigned pins as well as details on the available prefab cables.

- The first column describes both the pin number of the connector and of the matching prefab maxon cable's Head A.
- The second column describes the cable core color of the prefab maxon cable.
- The third column describes the pin number of the prefab maxon cable's Head B.

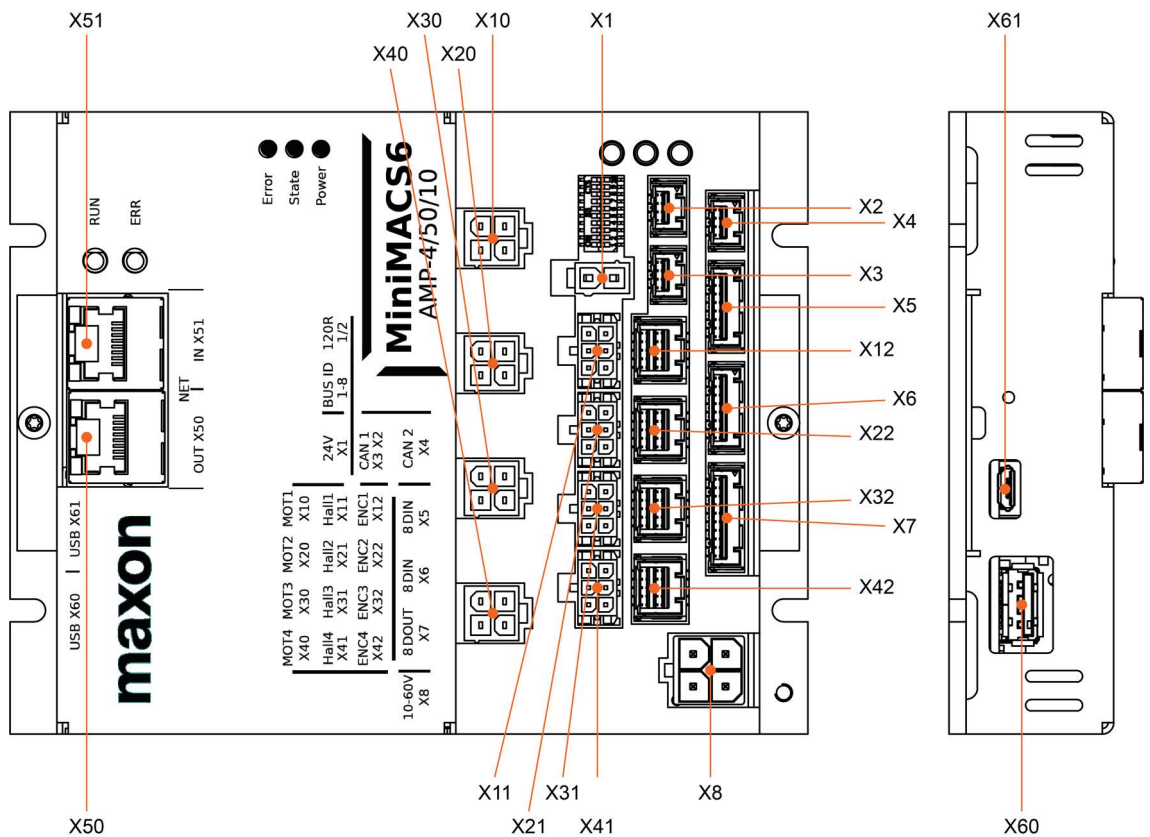

X1	Logic Supply →page 3-28	X11	Hall Sensor 1 →page 3-36
X2	CAN 1 →page 3-54	X21	Hall Sensor 2 →page 3-36
X3	CAN 1 →page 3-54	X31	Hall Sensor 3 →page 3-36
X4	CAN 2 →page 3-54	X41	Hall Sensor 4 →page 3-36
X5	Digital Inputs 1...8 →page 3-50	X12	Encoder 1 →page 3-38
X6	Digital Inputs 9...16 →page 3-50	X22	Encoder 2 →page 3-38
X7	Digital Outputs 1...8 →page 3-52	X32	Encoder 3 →page 3-38
X8	Power Supply →page 3-26	X42	Encoder 4 →page 3-38
X10	Motor 1 →page 3-29	X50	NET OUT →page 3-58
X20	Motor 2 →page 3-29	X51	NET IN →page 3-58
X30	Motor 3 →page 3-29	X60	USB 2 →page 3-57
X40	Motor 4 →page 3-29	X61	USB 1 →page 3-56

Figure 3-8 Connectors



**Simplified notation**

For ease of reading, in some cases the generic use of connectors is indicated as follows:

- «Xn0» will be used for connectors X10, X20, X30, and X40.
- «Xn1» will be used for connectors X11, X21, X31, and X41.
- «Xn2» will be used for connectors X12, X22, X32, and X42.

**3.4.1 Power Supply (X8)**

Basically, any power supply may be used provided that it meets the stated minimum requirements.

The power supply output must be electrically (galvanically) isolated and must meet the stated minimum requirements.

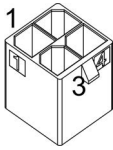

Figure 3-9 Power supply connector X8

Head A Pin	Prefab Cable Color	Head B Pin	Signal	Description
X8   1	black	+	+V <sub>cc</sub>	Power supply voltage (+10...+60 VDC)
X8   3	black	+		
X8   2	black	-	GND	Ground
X8   4	black	-		

Table 3-12 Power supply connector X8 – Pin assignment

Power Cable High Current (699485)		
Cross-section	4 x 2.5 mm <sup>2</sup> , grey	
Length	3 m	
Head A	Plug	Molex Mega-Fit, 4 poles (171692-0104)
	Contacts	Molex Mega-Fit, female crimp terminals (172063)
Head B	Wire end sleeves 2.5 mm <sup>2</sup>	

Table 3-13 Power Cable High Current

Continued on next page.

Power supply requirements	
Output voltage	+V <sub>CC</sub> 10...60 VDC
Absolute output voltage	min. 9 VDC; max. 66 VDC
Output current	Depending on load <ul style="list-style-type: none"> <li>• root mean square (rms) max. 40 A</li> <li>• continuous max. 40 A</li> <li>• short-time (acceleration, &lt;5 s) max. 120 A</li> </ul>

Table 3-14 Power supply requirements

- 1) Use the formula below to calculate the required voltage under load.
- 2) Choose a power supply according to the calculated voltage. Thereby consider:
  - a) During braking of the load, the power supply must be capable of buffering the recovered kinetic energy (for example, in a capacitor).
  - b) If you are using an electronically stabilized power supply, make sure that the overcurrent protection circuit is configured inoperative within the operating range.



**The formula already takes the following into account:**

- Maximum PWM duty cycle of 90%
- Controller's max. voltage drop of 1 V @ 10 A

**KNOWN VALUES:**

- Operating torque M [mNm]
- Operating speed n [rpm]
- Nominal motor voltage U<sub>N</sub> [Volt]
- Motor no-load speed at U<sub>N</sub>; n<sub>0</sub> [rpm]
- Speed/torque gradient of the motor Δn/ΔM [rpm/mNm]

**SOUGHT VALUE:**

- Supply voltage +V<sub>CC</sub> [Volt]

**SOLUTION:**

$$V_{CC} \geq \left[ \frac{U_N}{n_0} \cdot \left( n + \frac{\Delta n}{\Delta M} \cdot M \right) \cdot \frac{1}{0.9} \right] + 1 [V]$$

### 3.4.2 Logic Supply (X1)

The logic part of the controller must be supplied by a separate supply voltage.



#### Galvanic isolation

The logic supply must be electrically (galvanically) isolated from the power supply.

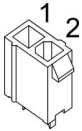

Figure 3-10 Logic supply connector X1

Head A Pin	Prefab Cable Color	Head B Pin	Signal	Description
X1   1	black	-	GND	Ground
X1   2	black	+	+V <sub>c</sub>	Logic supply voltage (+18...+30 VDC)

Table 3-15 Logic supply connector X1 – Pin assignment

Power Cable (275829)		
<b>A</b>		<b>B</b>
Cross-section	2 x 0.75 mm <sup>2</sup> , grey	
Length	3 m	
Head A	Plug	Molex Mini-Fit Jr., 2 poles (39-01-2020)
	Contacts	Molex Mini-Fit Jr. female crimp terminals (45750)
Head B	Wire end sleeves 0.75 mm <sup>2</sup>	

Table 3-16 Power Cable

Power supply requirements	
Output voltage	24 VDC
Absolute supply voltage	min. 18 VDC; max. 30 VDC
Min. output power	P <sub>c</sub> min. 100 W @ full load

Table 3-17 Power supply requirements

### 3.4.3 Motor (X10 / X20 / X30 / X40)

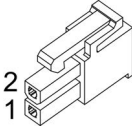
The controller is set to drive up to six DC motors (brushed DC motors), four EC motors (BLDC or PMSM, brushless DC motors), or three stepper motors. For high-output drives, individual motor connections can be paired to twins which almost doubles the controller’s rated output. Different types of motors can be combined if certain criteria are being met (find details in section →“Motor Combinations” on page 3-33).



#### Maximum permitted current

The connectors are designed for an output current  $I_{cont} \leq 10\text{ A}$ .



#### Notations used

- “EC” meaning operation in either BLDC mode or PMSM mode.
- “Twin” meaning parallel connection of two power stages resulting in performance increase of 150%.

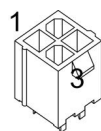

Figure 3-11 Motor connectors Xn0

Motor Cable (275851)		
<b>A</b>		<b>B</b>
Cross-section	3 x 0.75 mm <sup>2</sup> , shielded, grey	
Length	3 m	
Head A	Plug	Molex Mini-Fit Jr., 4 poles (39-01-2040)
	Contacts	Molex Mini-Fit Jr. female crimp terminals (45750)
Head B	Wire end sleeves 0.75 mm <sup>2</sup>	

Table 3-18 Motor Cable

## 3.4.3.1 DC Motors

Head A Pin	Prefab Cable Color	Head B Pin	Signal	Description
X10   1	white		Motor1 (+M1)	DC motor 1: Motor +
X10   2	brown		Motor1 (-M1)	DC motor 1: Motor -
X10   3	green		Motor5 (-M5)	DC motor 5: Motor -
X10   4	black		Motor shield	Cable shield
X20   1	white		Motor2 (+M2)	DC motor 2: Motor +
X20   2	brown		Motor2 (-M2)	DC motor 2: Motor -
X20   3	green		Motor5 (+M5)	DC motor 5: Motor +
X20   4	black		Motor shield	Cable shield
X30   1	white		Motor3 (+M3)	DC motor 3: Motor +
X30   2	brown		Motor3 (-M3)	DC motor 3: Motor -
X30   3	green		Motor6 (-M6)	DC motor 6: Motor -
X30   4	black		Motor shield	Cable shield
X40   1	white		Motor4 (+M4)	DC motor 4: Motor +
X40   2	brown		Motor4 (-M4)	DC motor 4: Motor -
X40   3	green		Motor6 (+M6)	DC motor 6: Motor +
X40   4	black		Motor shield	Cable shield

Table 3-19 Motor connectors Xn0 – Pin assignment for up to six DC motors

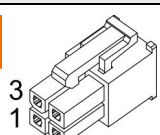
## 3.4.3.2 DC Twin Motors

Head A Pin	Prefab Cable Color	Head B Pin	Signal	Description
X10   1	white		Motor1 (+M1)	DC motor 1: Motor +
X10   2	brown		Motor1 (-M1)	DC motor 1: Motor -
X10   3	green		Motor2 (-M2)	DC motor 2: Motor -
X10   4	black		Motor shield	Cable shield
X20   1	white		Motor2 (+M2)	DC motor 2: Motor +
X20   2	brown		Motor2 (-M2)	DC motor 2: Motor -
X20   3	green		Motor2 (+M2)	DC motor 2: Motor +
X20   4	black		Motor shield	Cable shield
X30   1	white		Motor1 (+M1)	DC motor 1: Motor +
X30   2	brown		Motor1 (-M1)	DC motor 1: Motor -
X30   3	green		Motor4 (-M4)	DC motor 4: Motor -
X30   4	black		Motor shield	Cable shield
X40   1	white		Motor4 (+M4)	DC motor 4: Motor +
X40   2	brown		Motor4 (-M4)	DC motor 4: Motor -
X40   3	green		Motor4 (+M4)	DC motor 4: Motor +
X40   4	black		Motor shield	Cable shield

Table 3-20 Motor connectors Xn0 – Pin assignment for up to three DC twin motors

### 3.4.3.3 Brake Choppers

Head A Pin	Prefab Cable Color	Head B Pin	Signal	Description
X10   1	white		Chopper1 (+C1)	Brake chopper 1: Chopper +
X10   2	brown		Chopper1 (-C1)	Brake chopper 1: Chopper -
X10   3	green		Chopper5 (-C5)	Brake chopper 5: Chopper -
X10   4	black		Motor shield	Cable shield
X20   1	white		Chopper2 (+C2)	Brake chopper 2: Chopper +
X20   2	brown		Chopper2 (-C2)	Brake chopper 2: Chopper -
X20   3	green		Chopper5 (+C5)	Brake chopper 5: Chopper +
X20   4	black		Motor shield	Cable shield
X30   1	white		Chopper3 (+C3)	Brake chopper 3: Chopper +
X30   2	brown		Chopper3 (-C3)	Brake chopper 3: Chopper -
X30   3	green		Chopper6 (-C6)	Brake chopper 6: Chopper -
X30   4	black		Motor shield	Cable shield
X40   1	white		Chopper4 (+C4)	Brake chopper 4: Chopper +
X40   2	brown		Chopper4 (-C4)	Brake chopper 4: Chopper -
X40   3	green		Chopper6 (+C6)	Brake chopper 6: Chopper +
X40   4	black		Motor shield	Cable shield

Table 3-21 Motor connectors Xn0 – Pin assignment for up to six brake choppers

### 3.4.3.4 EC (BLDC or PMSM) Motors

**Make sure that the wiring of the parallel half bridges will be done carefully.  
The current must be divided as equal as possible between the two half bridges.**

Head A Pin	Prefab Cable Color	Head B Pin	Signal	Description
X10   1	white		Motor1 (U1)	EC motor 1: Winding 1
X10   2	brown		Motor1 (V1)	EC motor 1: Winding 2
X10   3	green		Motor1 (W1)	EC motor 1: Winding 3
X10   4	black		Motor shield	Cable shield
X20   1	white		Motor2 (U2)	EC motor 2: Winding 1
X20   2	brown		Motor2 (V2)	EC motor 2: Winding 2
X20   3	green		Motor2 (W2)	EC motor 2: Winding 3
X20   4	black		Motor shield	Cable shield
X30   1	white		Motor3 (U3)	EC motor 3: Winding 1
X30   2	brown		Motor3 (V3)	EC motor 3: Winding 2
X30   3	green		Motor3 (W3)	EC motor 3: Winding 3
X30   4	black		Motor shield	Cable shield
X40   1	white		Motor4 (U4)	EC motor 4: Winding 1

Continued on next page.

Head A Pin	Prefab Cable Color	Head B Pin	Signal	Description
X40   2	brown		Motor4 (V4)	EC motor 4: Winding 2
X40   3	green		Motor4 (W4)	EC motor 4: Winding 3
X40   4	black		Motor shield	Cable shield

Table 3-22 Motor connectors Xn0 – Pin assignment for up to four EC (BLDC, PMSM) motors

### 3.4.3.5 EC (BLDC or PMSM) Twin Motors

***Make sure that the wiring of the parallel half bridges will be done carefully.  
The current must be divided as equal as possible between the two half bridges.***

Head A Pin	Prefab Cable Color	Head B Pin	Signal	Description
X10   1	white		Motor1 (U1)	EC motor 1: Winding 1
X10   2	brown		Motor1 (V1)	EC motor 1: Winding 2
X10   3	green		Motor1 (W1)	EC motor 1: Winding 3
X10   4	black		Motor shield	Cable shield
X20   1	white		Motor1 (U1)	EC motor 1: Winding 1
X20   2	brown		Motor1 (V1)	EC motor 1: Winding 2
X20   3	green		Motor1 (W1)	EC motor 1: Winding 3
X20   4	black		Motor shield	Cable shield
X30   1	white		Motor2 (U2)	EC motor 2: Winding 1
X30   2	brown		Motor2 (V2)	EC motor 2: Winding 2
X30   3	green		Motor2 (W2)	EC motor 2: Winding 3
X30   4	black		Motor shield	Cable shield
X40   1	white		Motor2 (U2)	EC motor 2: Winding 1
X40   2	brown		Motor2 (V2)	EC motor 2: Winding 2
X40   3	green		Motor2 (W2)	EC motor 2: Winding 3
X40   4	black		Motor shield	Cable shield

Table 3-23 Motor connectors Xn0 – Pin assignment for up to two EC (BLDC, PMSM) twin motors

### 3.4.3.6 Stepper Motors

Head A Pin	Prefab Cable Color	Head B Pin	Signal	Description
X10   1	white		Motor1 (+A1)	Stepper motor 1: Motor +
X10   2	brown		Motor1 (-A1)	Stepper motor 1: Motor -
X10   3	green		Motor2 (-B2)	Stepper motor 2: Motor +
X10   4	black		Motor shield	Cable shield
X20   1	white		Motor2 (+A2)	Stepper motor 2: Motor +

Continued on next page.



Head A Pin	Prefab Cable Color	Head B Pin	Signal	Description
X20   2	brown		Motor2 (-A2)	Stepper motor 2: Motor -
X20   3	green		Motor2 (+B2)	Stepper motor 2: Motor -
X20   4	black		Motor shield	Cable shield
X30   1	white		Motor1 (+B1)	Stepper motor 1: Motor +
X30   2	brown		Motor1 (-B1)	Stepper motor 1: Motor -
X30   3	green		Motor4 (-B4)	Stepper motor 4: Motor +
X30   4	black		Motor shield	Cable shield
X40   1	white		Motor4 (+A4)	Stepper motor 4: Motor +
X40   2	brown		Motor4 (-A4)	Stepper motor 4: Motor -
X40   3	green		Motor4 (+B4)	Stepper motor 4: Motor -
X40   4	black		Motor shield	Cable shield

Table 3-24 Motor connectors Xn0 – Pin assignment for up to three stepper motors

3.4.3.7 Motor Combinations



**Mandatory criteria for connection of motors**

Motors can be configured in numerous constellations, provided that the following criteria are being met:

- Each connection pin may only be used once!
- Each motor number may only be used once!
- Each axis is linked to a motor (axis number = motor number -1).



**Notations used**

- “EC” meaning operation in either BLDC mode or PMSM mode.
- “Twin” meaning parallel connection of two power stages resulting in performance increase of 150%, 180% under special conditions, respectively.



**[i] Support for twin stepper motors is available on request**

The below matrix uses the following color code:

Axis 0 Motor 1	Axis 1 Motor 2	Axis 2 Motor 3	Axis 3 Motor 4	Axis 4 Motor 5	Axis 5 Motor 6
-------------------	-------------------	-------------------	-------------------	-------------------	-------------------

Pin	DC	Twin DC	EC	Twin EC	Stepper	Twin Stepper [k]	Brake Chopper
X10   1	+M1	+M1	U1	U1	+A1	—	+C1
X10   2	-M1	-M1	V1	V1	-A1	—	-C1
X10   3	-M5	-M2	W1	W1	-B2	—	-C5
X10   4	Motor shield						
X20   1	+M2	+M2	U2	U1	+A2	—	+C2
X20   2	-M2	-M2	V2	V1	-A2	—	-C2
X20   3	+M5	+M2	W2	W1	+B2	—	+C5
X20   4	Motor shield						
X30   1	+M3	+M1	U3	U3	+B1	—	+C3
X30   2	-M3	-M1	V3	V3	-B1	—	-C3
X30   3	-M6	-M4	W3	W3	-B4	—	-C6
X30   4	Motor shield						
X40   1	+M4	+M4	U4	U3	+A4	—	+C4
X40   2	-M4	-M4	V4	V3	-A4	—	-C4
X40   3	+M6	+M4	W4	W3	+B4	—	+C6
X40   4	Motor shield						

Table 3-25 Motor connectors Xn0 – Motor combination matrix

### 3.4.3.8 Limitation of PWM Duty Cycle

To ensure accurate current setting, the PWM duty cycle is limited. The maximum duty cycle level falls between 80% and 88%, depending on the motor type and axis number. Refer to → chapter “Table 3-26 Maximum duty cycle levels for different motor types and axis numbers” on page 3-35 for specific values. To calculate the maximum voltage, use the formula:

$$V_{Load} = K \times V_{cc}$$

**Example:** If the maximum duty cycle level is set at 88 % and the power voltage is 24 V, the average output voltage at the motor can never rise above 21.1 V.

Axis [j]	DC	Twin DC	EC	Twin EC	Stepper	Twin Stepper [k]	Brake Chopper
0	0.88	0.8	0.88	0.8	0.8	–	0.88
1	0.88	0.88	0.88	n/a	0.88	–	0.88
2	0.88	n/a	0.88	0.8	n/a	–	0.88
3	0.88	0.88	0.88	n/a	0.88	–	0.88
4	0.88	n/a	n/a	n/a	n/a	–	0.88
5	0.88	n/a	n/a	n/a	n/a	–	0.88

[j] The assignment of the axis and the motor combination can be checked in → chapter “Table 3-25 Motor connectors Xn0 – Motor combination matrix” on page 3-34.

[k] Support for twin stepper motors is available on request

Table 3-26 Maximum duty cycle levels for different motor types and axis numbers

### 3.4.4 Hall Sensor (X11 / X21 / X31 / X41)

Suitable Hall effect sensors IC use «Schmitt trigger» with open collector output.

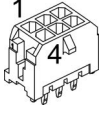

Figure 3-12 Hall sensor connectors Xn1

Head A Pin	Prefab Cable Color	Head B Pin	Signal	Description
Xn1   1	green		Hall sensor 1	Hall sensor 1 input
Xn1   2	brown		Hall sensor 2	Hall sensor 2 input
Xn1   3	white		Hall sensor 3	Hall sensor 3 input
Xn1   4	yellow		GND	Ground
Xn1   5	grey		$V_{\text{Sensor}}$	Sensor supply voltage (+5 VDC; $I_L \leq 1$ A for the total of all Hall sensors and encoders combined)
Xn1   6	black		Hall shield	Cable shield

Table 3-27 Hall sensor connectors Xn1 – Pin assignment

Hall Sensor Cable (275878)		
Cross-section	5 x 0.14 mm <sup>2</sup> , shielded, grey	
Length	3 m	
Head A	Plug	Molex Micro-Fit 3.0, 6 poles (430-25-0600)
	Contacts	Molex Micro-Fit 3.0 female crimp terminals (430-30-xxxx)
Head B	Wire end sleeves 0.14 mm <sup>2</sup>	

Table 3-28 Hall Sensor Cable

Continued on next page.

Hall sensor	
Sensor supply voltage ( $V_{\text{Sensor}}$ )	+5 VDC
Max. sensor supply current	1 A (for the total of all Hall sensors and encoders combined)
Input voltage	0...24 VDC
Max. input voltage	+24 VDC
Logic 0	typically <0.8 V
Logic 1	typically >2.0 V
Internal pull-up resistor	2.7 k $\Omega$ (referenced to +5.0 V – 0.6 V)

Table 3-29 Hall sensor specification

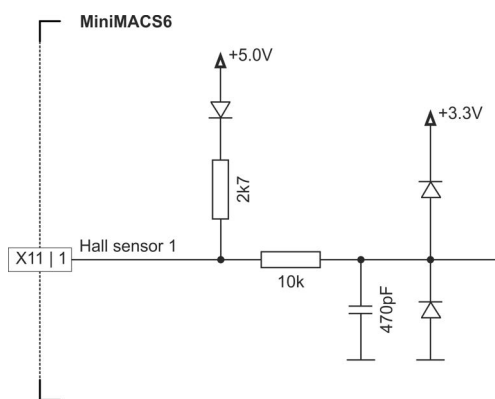

Figure 3-13 Hall sensor 1 input circuit (analogously valid for Hall sensors 2 & 3 and other Xn1)

### 3.4.5 Encoder (X12 / X22 / X32 / X42)

Additional sensors, both incremental and serial encoders, can be connected.

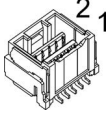

Figure 3-14 Encoder connectors Xn2

Head A Pin	Prefab Cable Color	Head B Pin	Signal	Description
Xn2   1 Xn2   7	white blue	1 7	Channel A	Digital/analog incremental encoder channel A
			Data	Data (SSI)
			Channel A Master	Incremental master encoder channel A
Xn2   2 Xn2   8	brown red	2 8	Channel A\	Digital/analog incremental encoder channel A complement
			Data\	Data (SSI) complement
			Channel A\ Master	Incremental master encoder channel A complement
Xn2   3	green	3	Channel B	Digital/analog incremental encoder channel B
Xn2   4	yellow	4	Channel B\	Digital/analog incremental encoder channel B complement
Xn2   5	grey	5	Channel I	Digital/analog incremental encoder channel I
			Clock	Clock (SSI)
			Channel B Master	Incremental master encoder channel B
Xn2   6	pink	6	Channel I\	Digital/analog incremental encoder channel I complement
			Clock\	Clock (SSI) complement
			Channel B\ Master	Incremental master encoder channel B complement
Xn2   9	black	9	GND	Ground
Xn2   10	violet	10	V <sub>Sensor</sub>	Sensor supply voltage (+5 VDC; I <sub>L</sub> ≤ 1 A for the total of all Hall sensors and encoders combined)

Table 3-30 Encoder connectors Xn2 – Pin assignment

Sensor Cable 5x2core (520852)		
Cross-section	5 x 2 x 0.14 mm <sup>2</sup> , twisted pair, grey	
Length	3 m	
Head A	Plug	Molex CLIK-Mate, dual row, 10 poles (503149-1000)
	Contacts	Molex CLIK-Mate crimp terminals (502579)
Head B	Wire end sleeves 0.14 mm <sup>2</sup>	

Table 3-31 Sensor Cable 5x2core

### 3.4.5.1 Digital Incremental Encoder

Digital incremental encoder (differential)	
Sensor supply voltage ( $V_{\text{Sensor}}$ )	+5 VDC
Max. sensor supply current	1 A (for the total of all Hall sensors and encoders combined)
Min. differential input voltage	$\pm 200$ mV
Max. input voltage	+5 VDC
Line receiver (internal)	EIA RS422 standard
Max. input frequency	6.25 MHz

Table 3-32 Differential digital incremental encoder specification

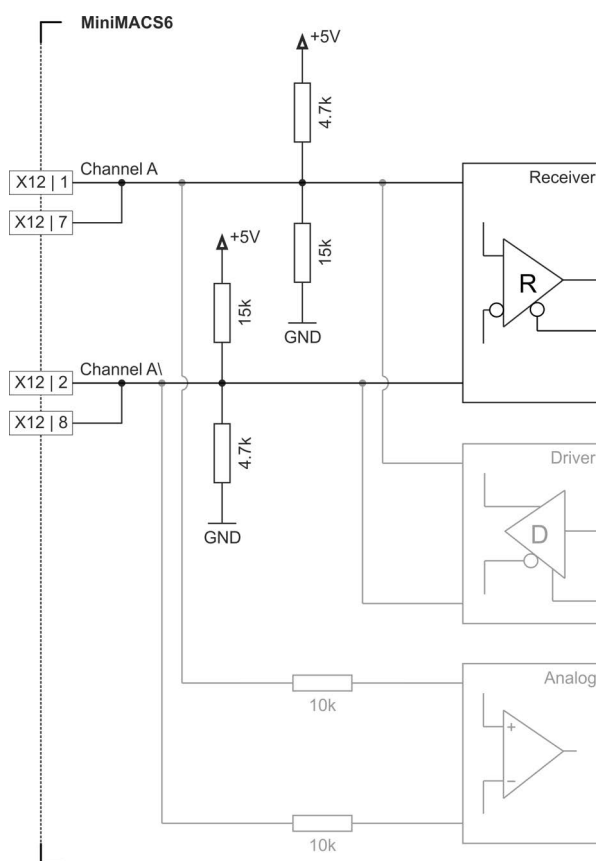

Figure 3-15 Digital incremental encoder input circuit Ch A “differential” (analogously valid for Ch I and other Xn2)

Continued on next page.

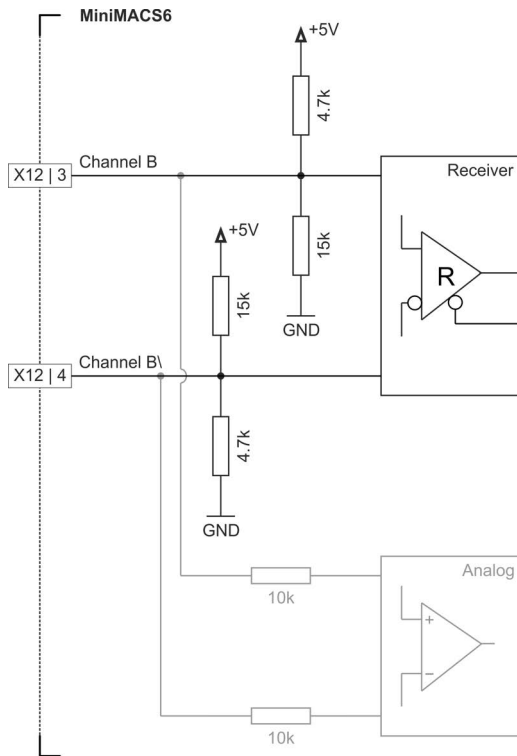

Figure 3-16 Digital incremental encoder input circuit Ch B “differential” (analogously valid for other Xn2)



Digital incremental encoder (single-ended)	
Sensor supply voltage ( $V_{\text{Sensor}}$ )	+5 VDC
Max. sensor supply current	1 A (for the total of all Hall sensors and encoders combined)
Input voltage	0...5 VDC
Max. input voltage	$\pm 5$ VDC
Switch level	1.5 V
Switch hysteresis	45 mV

Table 3-33 Single-ended digital incremental encoder specification

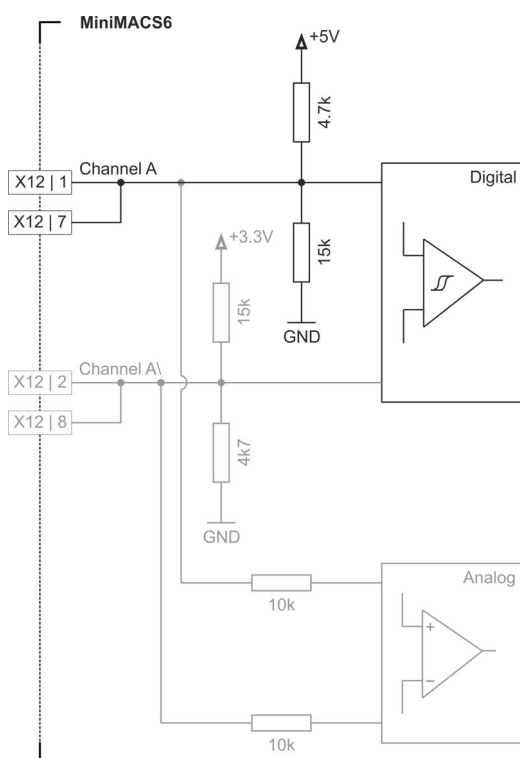

Figure 3-17 Digital incremental encoder input circuit Ch A “single-ended” (analogously valid for Ch B and other Xn2)

Continued on next page.

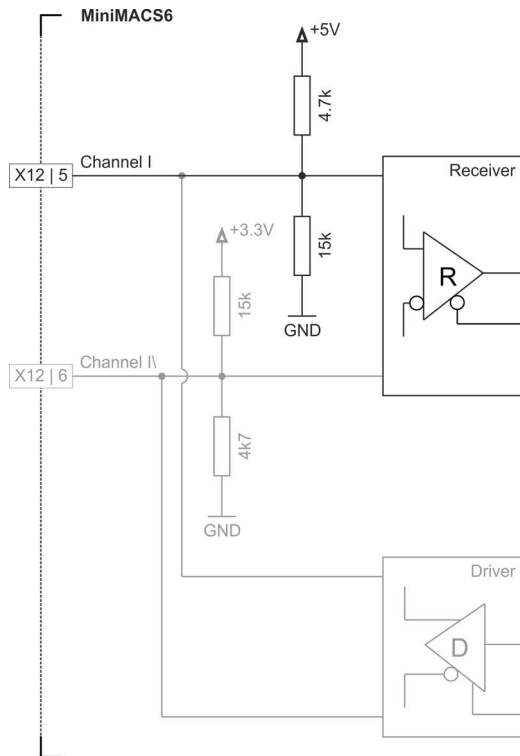

Figure 3-18 Digital incremental encoder input circuit Ch I (analogously valid for other Xn2)

3.4.5.2 Analog Incremental Encoder SinCos

Analog incremental encoder SinCos (differential)	
Sensor supply voltage ( $V_{\text{Sensor}}$ )	+5 VDC
Max. sensor supply current	1 A (for the total of all Hall sensors and encoders combined)
Input voltage	$\pm 1.2$ V (differential)
Max. input voltage	0...5 VDC
Common mode voltage	0...+4 VDC (referenced to GND)
Input resistance	typically 10 k $\Omega$
A/D converter	12-bit
Resolution	0.81 mV
Max. input frequency	Analog SinCos encoding: $\leq 20$ kHz
	Quadrature encoding: 20...150 kHz

Table 3-34 Differential analog incremental encoder specification

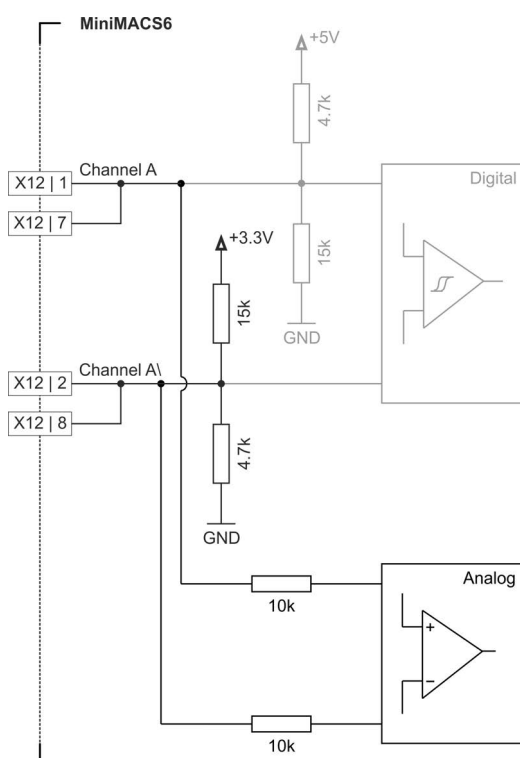

Figure 3-19 Analog incremental encoder input circuit Ch A “differential” (analogously valid for Ch B and other Xn2)

Continued on next page.

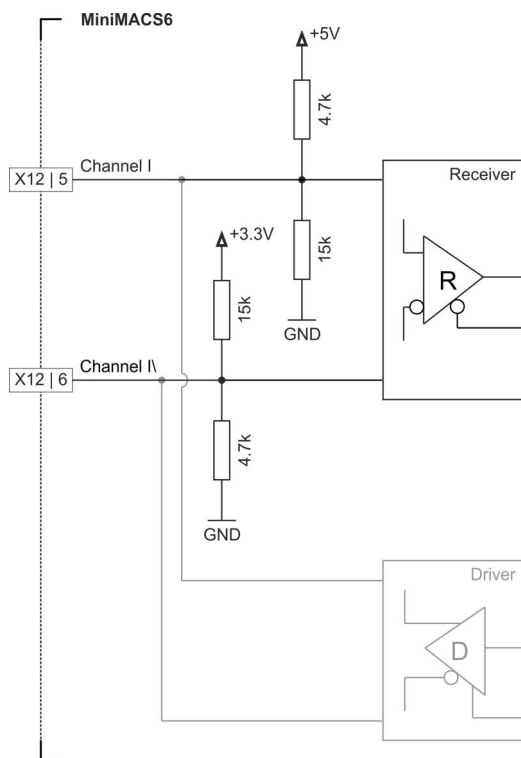

Figure 3-20 Analog incremental encoder input circuit Ch I (digital evaluation, analogously valid for other Xn2)

3.4.5.3 SSI Absolute Encoder

SSI absolute encoder	
Sensor supply voltage ( $V_{\text{Sensor}}$ )	+5 VDC
Max. sensor supply current	1 A (for the total of all Hall sensors and encoders combined)
Min. differential input voltage	$\pm 45$ mV
Min. differential output voltage	$\pm 1.8$ V @ external load $R=54 \Omega$
Max. output current	40 mA
Line receiver (internal)	EIA RS422 standard
Clock frequency	39 kHz...5 MHz

Table 3-35 SSI absolute encoder specification

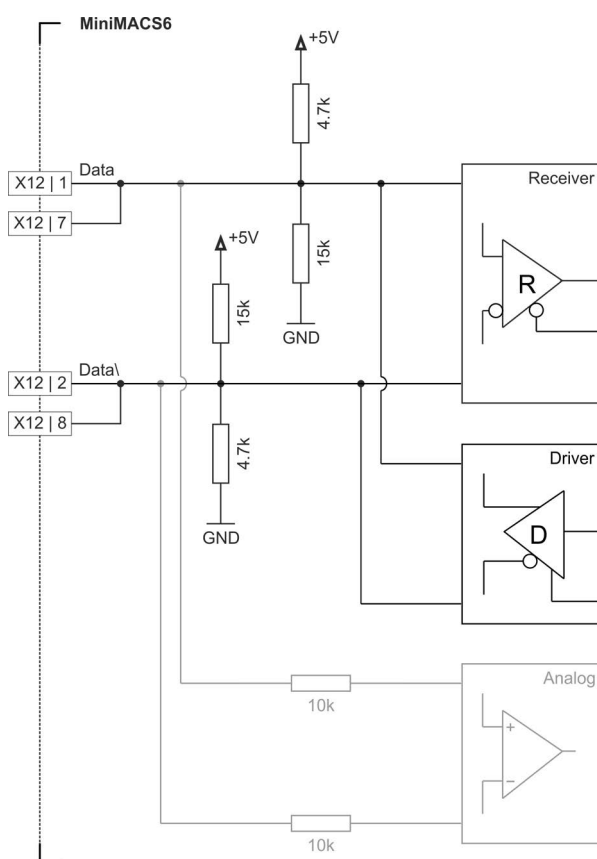

Figure 3-21 SSI absolute encoder data input (analogously valid for other Xn2)

Continued on next page.

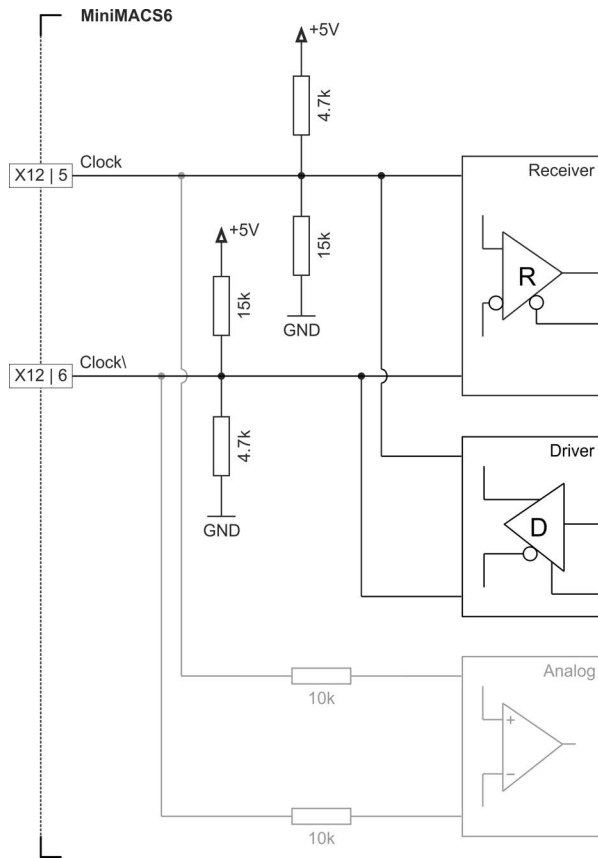

Figure 3-22 SSI absolute encoder clock output (analogously valid for other Xn2)

**3.4.5.4 Digital Incremental Master Encoder**

The MiniMACS6-AMP-4/50/10 is able to emulate incremental encoder signals at the digital incremental master encoder outputs.

Digital incremental encoder (differential)	
Sensor supply voltage ( $V_{\text{Sensor}}$ )	+5 VDC
Max. sensor supply current	1 A (for the total of all Hall sensors and encoders combined)
Min. differential output voltage	min. +/-1 V @ $R_L = 100 \Omega$
Output voltage	+5 VDC
Line transceiver (internal)	EIA RS422 standard
Max. output frequency	1 Hz ... 600 kHz +/- 4 %

Table 3-36 Differential digital incremental encoder specification

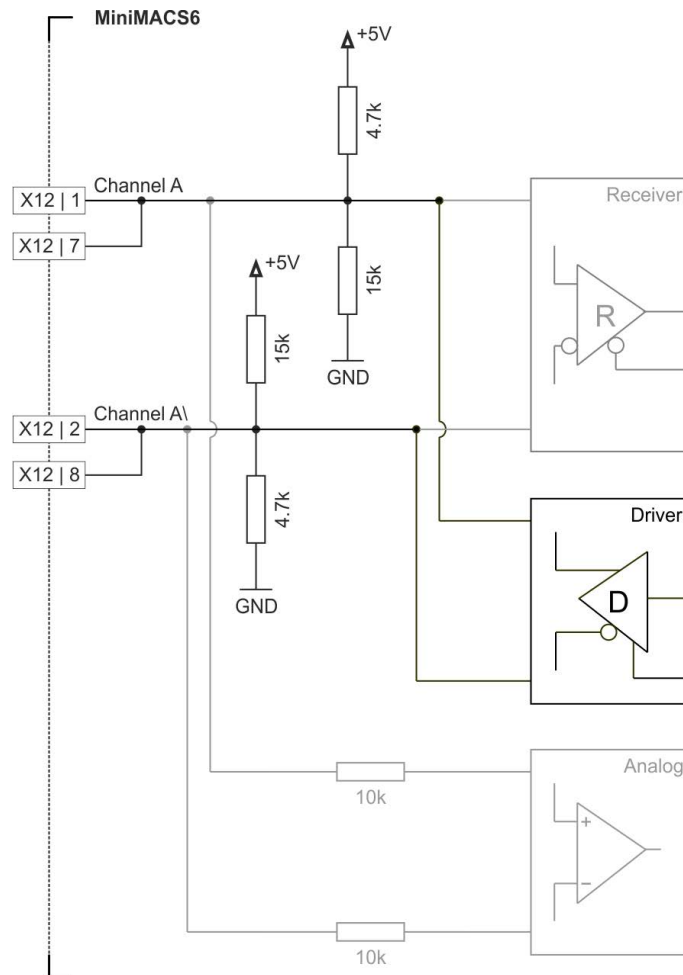

Figure 3-23 Digital incremental master encoder input circuit Ch B is still an input identical to the → Digital Incremental Encoder

### 3.5 Encoder Input Glitch Filter

The MiniMACS6-AMP-4/50/10 offers glitch filters for incremental encoder inputs and for the quadrature encoding of SinCos signals. The filter has no effect on the analog encoding of SinCos signals. There is no filter available for SSI Encoders. Adding a filter leads to always to a signal delay, which could lead in a wrong configuration to encoding failures especially for SinCos signals. The filter gets disabled or configured with the HWENCODER\_GLITCHFILT SDO out of the AposSIDE® application. As default the filter is for all axis disabled.

HWENCODER_GLITCHFILT SDO			
Bits 15..13	Bits 12..11	Bits 10..8	Bits 7..0
FILT_PRSC	—	FILT_CNT	FILT_PER

Table 3-37 Parameter value diagram

#### 3.5.1 Fields

Field	Function
15-13 FILT_PRSC	<p>Prescaler divide IPbus clock to FILT clk</p> <p>The Prescaler field is used to prescale the 132 MHz clock to FILT clock. The 132 MHz clock is prescaled by a value of <math>2^{\text{FILT\_PRSC}}</math> which means that the prescaler logic can divide the clock by a minimum of 1 (default) and a maximum of 128. FILTER can fit lower freq noise.</p>
12-11 —	Reserved
10-8 FILT_CNT	<p>Input Filter Sample Count</p> <p>The Input Filter Sample Count represents the number of consecutive samples that must agree, before the input filter accepts an input transition.</p> <ul style="list-style-type: none"> <li>• A value of 0x0 represents 3 samples (default)</li> <li>• A value of 0x7 represents 10 samples</li> </ul> <p>The value of the Input Filter Sample Count (FILT_CNT) affects the input latency.</p>
7-0 FILT_PER	<p>Input Filter Sample Period</p> <p>The Input Filter Sample Period represents the sampling period (in FILT clock cycles) of the decoder input signals. Each input is sampled multiple times at the rate specified by the Input Filter Sample Period.</p> <ul style="list-style-type: none"> <li>• If FILT_PER is 0x00 (default), then the input filter is bypassed. Bypassing the digital filter enables the position/position difference counters to operate with count rates up to 132 MHz.</li> <li>• The value of the Input Filter Sample Period (FILT_PER) affects the input latency.</li> <li>• When changing the Input Filter Sample Period (FILT_PER) from a non-zero value to another non zero value, write a value of 0 first, to clear the filter.</li> <li>• Filter Sample Periods from 1 till 255 are configurable.</li> </ul>

Table 3-38 Parameter value diagram



### 3.5.2 Filter calculation

$$SamplePeriod = \frac{[FILT-PRSC] \times 2^{[FILT-PRSC]}}{132MHz} = \begin{bmatrix} max247.27us \\ min7.57ns \end{bmatrix}$$

$$maxDelay = SamplePeriod \times ([FILT-CNT] + 3) + \frac{1}{132MHz} = \begin{bmatrix} max2472.7us \\ min30.30ns \end{bmatrix}$$

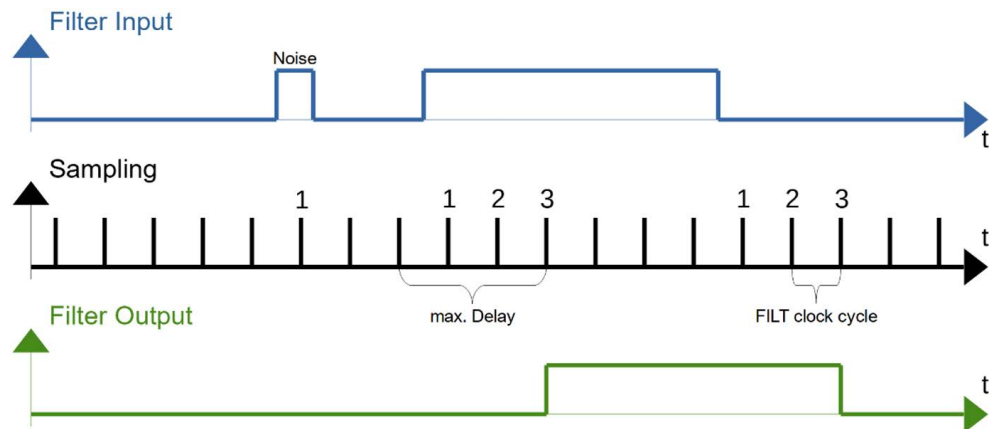

Figure 3-24 Glitch filter sequence diagram

### 3.5.3 Digital Inputs (X5 / X6)

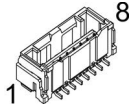

Figure 3-25 Digital input connectors X5, X6

Head A Pin	Prefab Cable Color	Head B Pin	Signal	Description
X5   1	white	1	DigIN1	Digital input 1 with encoder latch function
X5   2	brown	2	DigIN2	Digital input 2 with encoder latch function
X5   3	green	3	DigIN3	Digital input 3 with encoder latch function
X5   4	yellow	4	DigIN4	Digital input 4 with encoder latch function
X5   5	grey	5	DigIN5	Digital input 5
X5   6	pink	6	DigIN6	Digital input 6
X5   7	blue	7	DigIN7	Digital input 7
X5   8	red	8	DigIN8	Digital input 8

Table 3-39 Digital input connector X5 – Pin assignment

Head A Pin	Prefab Cable Color	Head B Pin	Signal	Description
X6   1	white	1	DigIN9	Digital input 9 (optional AnIN1, analog input 1)
X6   2	brown	2	DigIN10	Digital input 10 (optional AnIN2, analog input 2)
X6   3	green	3	DigIN11	Digital input 11 (optional AnIN3, analog input 3)
X6   4	yellow	4	DigIN12	Digital input 12 (optional AnIN4, analog input 4)
X6   5	grey	5	DigIN13	Digital input 13
X6   6	pink	6	DigIN14	Digital input 14
X6   7	blue	7	DigIN15	Digital input 15
X6   8	red	8	DigIN16	Digital input 16

Table 3-40 Digital input connector X6 – Pin assignment

Signal Cable 8core (520853)		
<b>A</b>		<b>B</b>
Cross-section	8 x 0.14 mm <sup>2</sup> , grey	
Length	3 m	
Head A	Plug	Molex CLIK-Mate, single row, 8 poles (502578-0800)
	Contacts	Molex CLIK-Mate crimp terminals (502579)
Head B	Wire end sleeves 0.14 mm <sup>2</sup>	

Table 3-41 Signal Cable 8core

Digital inputs 1...16	
Input voltage	0...30 VDC
Max. input voltage	+30 VDC
Input current at logic 1	typically 1 mA @ 24 VDC
Switching delay	<1 ms @ 24 VDC

Table 3-42 Digital input specification

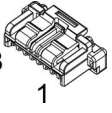
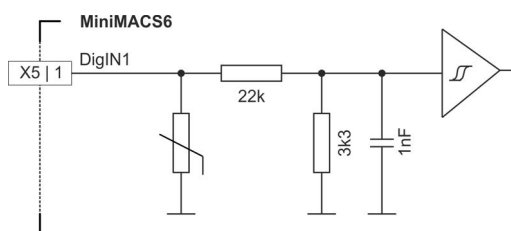

Figure 3-26 DigIN1 circuit (analogously valid for DigIN2...16 and X6)

Analog inputs 1...4 (optional settings on digital inputs 9...12)	
Input voltage	0...10 VDC
Max. input voltage	+24 VDC
Input resistance	25 kΩ (referenced to GND)
A/D converter	12-bit
Resolution	2.97 mV

Table 3-43 Analog input specification

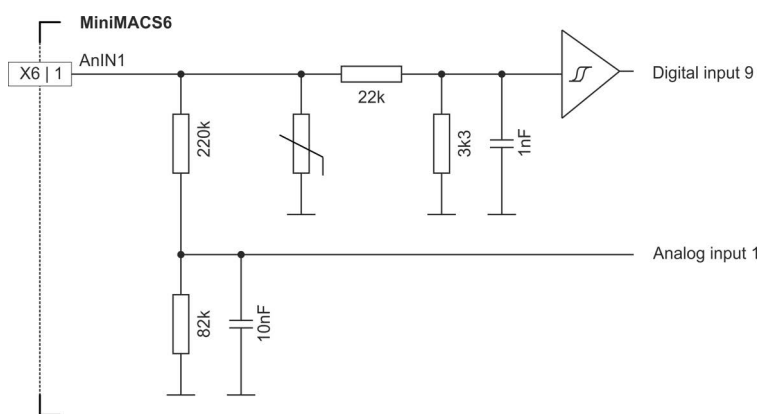

Figure 3-27 AnIN1 circuit (analogously valid for AnIN2...4)

### 3.5.4 Digital Outputs (X7)

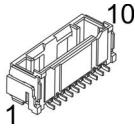

Figure 3-28 Digital output connector X7

Head A Pin	Prefab Cable Color	Head B Pin	Signal	Description
X7   1	white	1	DigOUT1	Digital output 1
X7   2	brown	2	DigOUT2	Digital output 2
X7   3	green	3	DigOUT3	Digital output 3
X7   4	yellow	4	DigOUT4	Digital output 4
X7   5	grey	5	DigOUT5	Digital output 5
X7   6	pink	6	DigOUT6	Digital output 6
X7   7	blue	7	DigOUT7	Digital output 7
X7   8	red	8	DigOUT8	Digital output 8
X7   9	black	9	V <sub>IO</sub>	Digital I/O output voltage (+24 VDC; I <sub>L</sub> ≤1 A) (AMP4 supplies sensors)
X7   10	grey- pink	10	GND	Ground

Table 3-44 Digital output connector X7 – Pin assignment

Signal Cable 10core (696837)		
Cross-section	10 x 0.14 mm <sup>2</sup> , grey	
Length	3 m	
Head A	Plug	Molex CLIK-Mate, single row, 10 poles (502578-1000)
	Contacts	Molex CLIK-Mate crimp terminals (502579)
Head B	Wire end sleeves 0.14 mm <sup>2</sup>	

Table 3-45 Signal Cable 10core

Continued on next page.

Digital outputs 1...8	
Circuit	Open source (24 VDC; 100 mA)

Table 3-46 Digital output specification

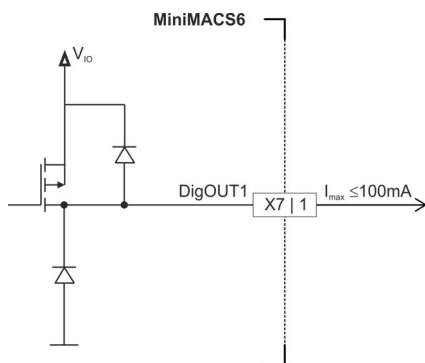

Figure 3-29 DigOUT1 circuit (analogously valid for DigOUT2...8)

### WIRING EXAMPLE

Digital I/O output voltage	
Output voltage	+24 VDC
Max. load current	100 mA
Max. voltage drop	0.5 V @ 100 mA

Table 3-47 Digital I/O output voltage specification

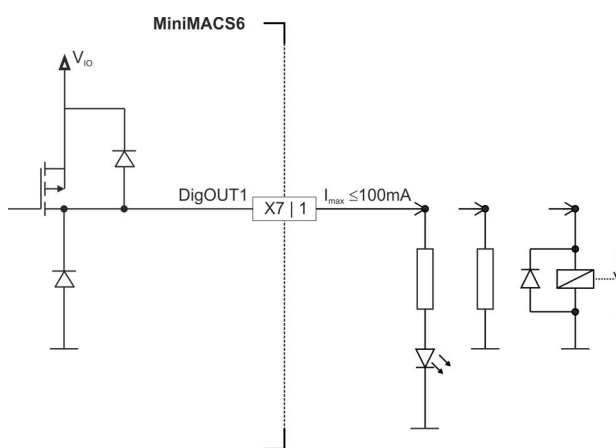

Figure 3-30 DigOUT1 "source" (analogously valid for DigOUT2...8)

### 3.5.5 STO

coming soon

The Safe Torque Off (STO) functionality will be implemented with an upcoming hardware release.

### 3.5.6 CAN 1 (X2 / X3) & CAN 2 (X4)

The MiniMACS6-AMP-4/50/10 is specially designed being commanded and controlled or to command and control other devices via a Controller Area Network (CAN), a highly efficient data bus very common in all fields of automation and motion control. It is preferably used as a slave node in the CANopen network. The MiniMACS6-AMP-4/50/10 features an additional CAN port to address other slave devices, such as other motor controllers.

- CAN 1 acts as CANopen Master or Slave
- CAN 2 acts as CANopen Master, only

For CAN configuration see →“DIP Switch Configuration (SW1)” on page 3-60.

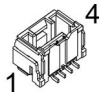

Figure 3-31 CAN 1 & CAN 2 connectors X2, X3, X4

Head A Pin	Prefab Cable Color	520857 Head B Pin	520858 Head B Pin	Signal	Description
X2   1 X3   1 X4   1	white	7	1	CAN high	CAN high bus line
X2   2 X3   2 X4   2	brown	2	2	CAN low	CAN low bus line
X2   3 X3   3 X4   3	green	3	3	GND	Ground
X2   4 X3   4 X4   4	Shield	5	4	Shield	Cable shield

Table 3-48 CAN 1 & CAN 2 connectors X2, X3, X4 – Pin assignment

CAN-COM Cable (520857)		
Cross-section	2 x 2 x 0.14 mm <sup>2</sup> , twisted pair, shielded	
Length	3 m	
Head A	Plug	Molex CLIK-Mate, single row, 4 poles (502578-0400)
	Contacts	Molex CLIK-Mate crimp terminals (502579)
Head B	Female D-Sub connector DIN 41652, 9 poles, with mounting screws	

Table 3-49 CAN-COM Cable

Continued on next page.



CAN-CAN Cable (520858)		
		
Cross-section	2 x 2 x 0.14 mm <sup>2</sup> , twisted pair, shielded	
Length	3 m	
Head A	Plug	Molex CLIK-Mate, single row, 4 poles (502578-0400)
	Contacts	Molex CLIK-Mate crimp terminals (502579)
Head B	Plug	Molex CLIK-Mate, single row, 4 poles (502578-0400)
	Contacts	Molex CLIK-Mate crimp terminals (502579)

Table 3-50 CAN-CAN Cable

CAN interface	
Standard	ISO 11898-2:2003
Max. bit rate	1 Mbit/s
Max. number of CAN nodes	127/31 (via software/hardware setting)
Protocol	CiA 301 version 4.2.0
Node-ID setting	By DIP switch or software

Table 3-51 CAN interface specification

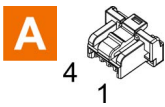

**Note**

- Consider the CAN master's maximal bit rate.
- The standard bit rate setting (factory setting) is 125 kbit/s.
- Make use of the 120 Ω onboard termination resistors at both ends of the CAN bus. You can select them using DIP switches 9 and 10 (for details → section "CAN Bus Termination" on page 3-62)

### 3.5.7 USB 1 (X61)



**Hot plugging the USB interface may cause hardware damage**

If the USB interface is being hot-plugged (connecting while the power supply is on), the possibly high potential differences of the two power supplies of controller and PC/Notebook can lead to damaged hardware.

- Avoid potential differences between the power supply of controller and PC/Notebook or, if possible, balance them.
- Insert the USB connector first, then switch on the power supply of the controller.

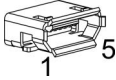

Figure 3-32 USB 1 connector X61

Head A Pin	PC's USB Terminal Head B Pin	Signal	Description
X61   1	1	V <sub>BUS</sub>	USB bus supply voltage input +5 VDC
X61   2	2	USB_D-	USB Data- (twisted pair with Data+)
X61   3	3	USB_D+	USB Data+ (twisted pair with Data-)
X61   4	–	ID	not connected
X61   5	4	GND	USB ground

Table 3-52 USB 1 connector X61 – Pin assignment

USB Type A - micro B Cable (403968)	
<b>A</b>	<b>B</b>
Cross-section	According to USB 2.0 / USB 3.0 specification
Length	1.5 m
Head A	USB Type "micro B", male
Head B	USB Type "A", male

Table 3-53 USB 1 Type A - micro B Cable

USB	
USB Standard	USB 2.0 (high speed)
Max. bus supply voltage	+5.25 VDC
Max. DC data input voltage	-0.5...+3.8 VDC

Table 3-54 USB interface specification



### 3.5.8 USB 2 (X60)

The interface provides connectivity to an external memory stick. Thereby, the memory stick serves the following purposes:

- Storage for process data
- Storage for user messages
- Storage for oscilloscope data
- Carrier for firmware updates to the MiniMACS6-AMP-4/50/10

The MiniMACS6-AMP-4/50/10 expects a memory stick formatted according to either FAT16 or FAT32 file system. For additional information see → «ApossIDE» Online Help; section “External Storage Device”.



#### **Hot plugging the USB interface may cause hardware damage**

*If the USB interface is being hot-plugged (connecting while the power supply is on), the possibly high potential differences of the two power supplies of controller and PC/Notebook can lead to damaged hardware.*

- *Avoid potential differences between the power supply of controller and PC/Notebook or, if possible, balance them.*
- *Insert the USB connector first, then switch on the power supply of the controller.*

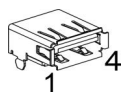

Figure 3-33 USB 2 connector X60

Head A Pin	PC's USB Terminal Head B Pin	Signal	Description
X60   1	1	+5V	USB bus supply voltage output +5 VDC
X60   2	2	USB_D-	USB Data- (twisted pair with Data+)
X60   3	3	USB_D+	USB Data+ (twisted pair with Data-)
X60   4	4	GND	USB ground

Table 3-55 USB 2 connector X60 – Pin assignment

### 3.5.9 NET OUT (X50) & NET IN (X51)

In combination with the optionally available «MiniMACS6-IF1» option card, the MiniMACS6-AMP-4/50/10-IF1 versions feature two NET connectors for extension communication interfaces, such as EtherCAT and Ethernet. Thereby, one serves for NET input, the other for NET output. Both sockets are identical in respect to their external wiring.

The respective loaded firmware defines whether the «MiniMACS6-IF1» option card acts as EtherCAT or as Ethernet.



**Wrong plugging may cause hardware damage**

*Even though both NET sockets are prepared for identical external wiring, make sure to always connect them as follows.*

- Use only standard Cat5 cables with RJ45 plug, such as maxon's «Ethernet Cable» (422827).
- Use X50 as «Output».
- Use X51 as «Input».

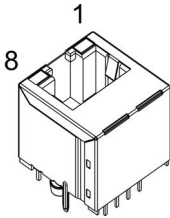

Figure 3-34 NET OUT & NET IN connectors X50, X51

Head A Pin	Prefab Cable Color	Head B Pin	Signal	Description
X50   1 X51   1	white/ orange	1	TX+	Transmission Data+
X50   2 X51   2	orange	2	TX-	Transmission Data-
X50   3 X51   3	white/ green	3	RX+	Receive Data+
X50   4 X51   4	blue	4	–	not applicable
X50   5 X51   5	white/ blue	5	–	not applicable
X50   6 X51   6	green	6	RX-	Receive Data-
X50   7 X51   7	white/ brown	7	–	not applicable
X50   8 X51   8	brown	8	–	not applicable

Table 3-56 NET OUT & NET IN connectors X50, X51 – Pin assignment

Continued on next page.

Ethernet Cable (422827)	
	
Cross-section	Cat. 5e SF/UTP (ISO/IEC 11801), 1:1 patch cable, green
Length	2 m
Head A	RJ45 (8P8CS) EIA/TIA-568B
Head B	RJ45 (8P8CS) EIA/TIA-568B

Table 3-57 Ethernet Cable

### 3.5.9.1 EtherCAT

To operate the «MiniMACS6-IF1» option card in an EtherCAT network, a corresponding firmware package with integrated EtherCAT function needs to be installed.

### 3.5.9.2 Ethernet

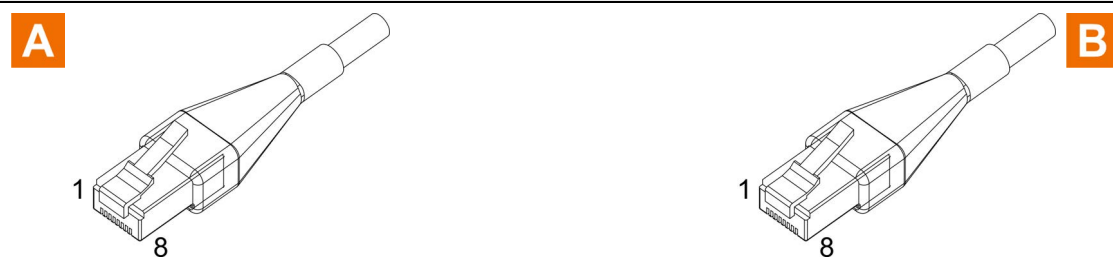
To operate the «MiniMACS6-IF1» option card in an Ethernet network, a corresponding firmware package with integrated Ethernet function needs to be installed.

The MiniMACS6-IF1 option card features an integrated Ethernet switch that allows to directly connect the next Ethernet device to Ethernet OUT (NET OUT; X50).



3.6.1 ID (Node-ID / CAN ID / DEV ID)



**Setting the ID**

- Switches #1 through #8 set the ID 1...255 by summing the values of the switch addresses 1 (“ON”).
- By setting the switches #1...#8 to 0 (“OFF”), the ID may be set by the «APOSS» application.
- **Switches #9 and #10 do not have any impact on the ID.**

Switch	Binary Code	Valence	Setting
1	2 <sup>0</sup>	1	
2	2 <sup>1</sup>	2	
3	2 <sup>2</sup>	4	
4	2 <sup>3</sup>	8	
5	2 <sup>4</sup>	16	
6	2 <sup>5</sup>	32	
7	2 <sup>6</sup>	64	
8	2 <sup>7</sup>	128	

Table 3-58 DIP switch SW1 – Binary code values

The set ID can be observed by adding the valence of all activated switches. Use the following table as a (non-concluding) guide:

Setting	Switch								ID
	1	2	3	4	5	6	7	8	
	0	0	0	0	0	0	0	0	1
	1	0	0	0	0	0	0	0	1
	1	1	0	0	0	0	0	0	3
	0	0	1	0	0	1	0	0	36
	0	1	1	0	1	0	1	0	86
	0	1	0	1	0	1	1	1	234
0 = Switch “OFF”      1 = Switch “ON”									

Table 3-59 DIP switch SW1 – Examples

### 3.6.2 CAN Bus Termination



#### Setting CAN bus termination

- Switch #9 sets the bus termination on CAN 1 using a 120 Ω resistor
- Switch #10 sets the bus termination on CAN 2 using a 120 Ω resistor
- **Switches #1 through #8 do not have any impact on the bus termination setting.**

Setting	Bus termination	
	CAN 1	CAN 2
<p>(factory setting)</p>	OFF	OFF
	<b>ON</b>	OFF
	OFF	<b>ON</b>
	<b>ON</b>	<b>ON</b>

Table 3-60 DIP switch SW1 – CAN bus termination

### 3.7 Status Indicators

The MiniMACS6-AMP-4/50/10 features a number of LED indicators to display the device condition.



**Note that LEDs marked [k] are only available with «MiniMACS6-IF1» option card.**

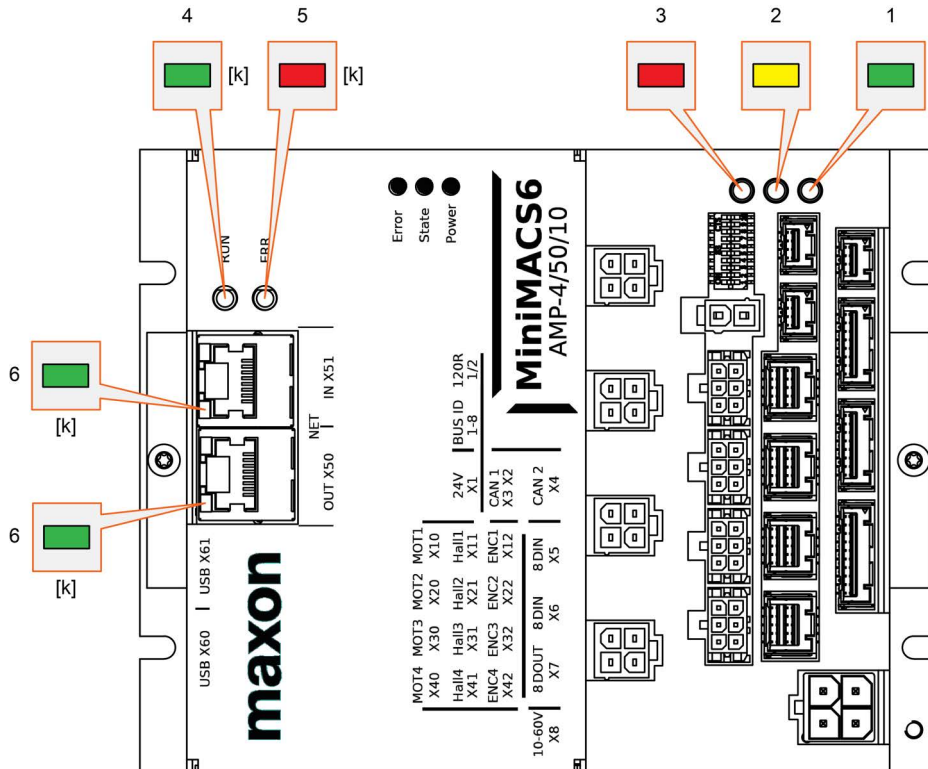

Figure 3-36 LEDs – Location

Continued on next page.





## 4 WIRING

In this section you will find the wiring information for the setup you are using. You can either use the consolidated wiring diagram (→ Figure 4-38) featuring the full scope of interconnectivity and pin assignment. Or you may wish to use the connection overviews for either DC motor or EC (BLDC or PMSM) motor that will assist you in determining the wiring for your particular motor type and the appropriate feedback signals.

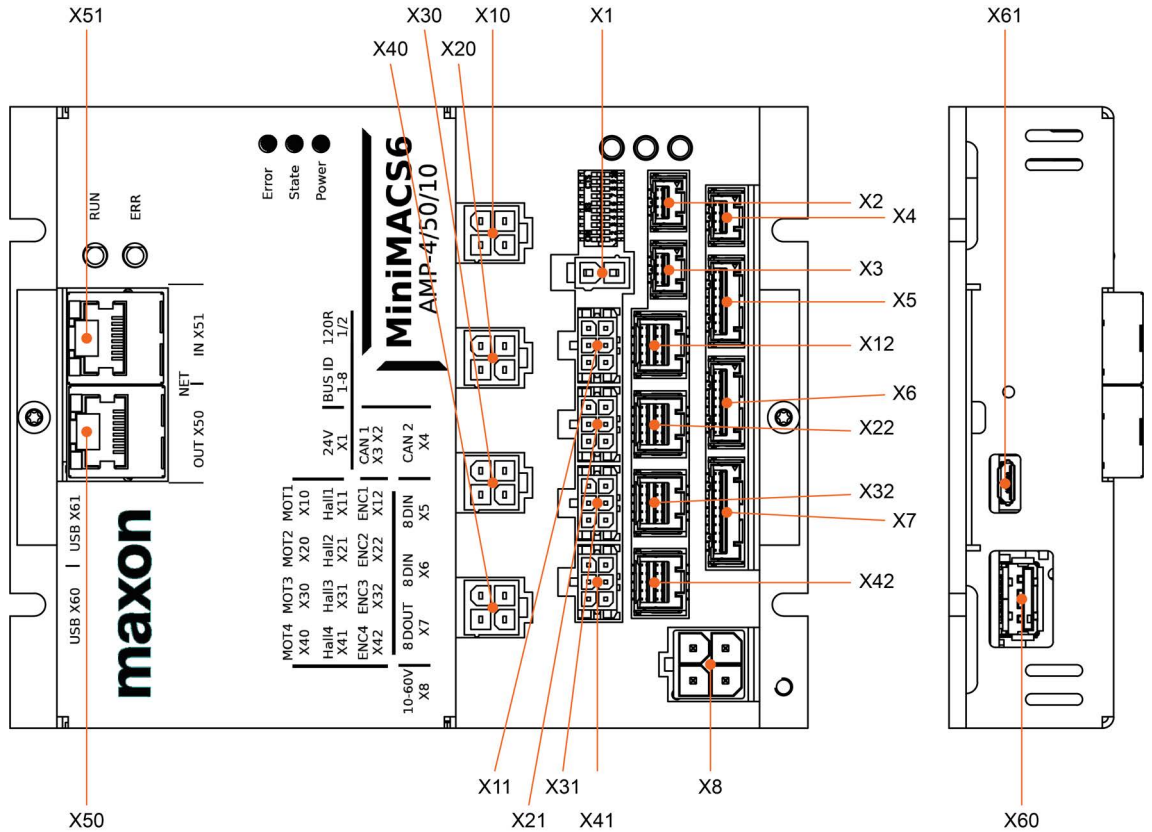

Figure 4-37 Interfaces – Designations and location



### Signs and abbreviations used

The subsequent diagrams feature these signs and abbreviations:

- «EC Motor» stands for brushless EC motor (BLDC or PMSM).
- Ground safety earth connection (optional).



### Simplified notation

For ease of reading, in some cases the generic use of connectors is indicated as follows:

- «Xn0» will be used for connectors X10, X20, X30, and X40.
- «Xn1» will be used for connectors X11, X21, X31, and X41.
- «Xn2» will be used for connectors X12, X22, X32, and X42.

## 4.1 Possible Combinations to connect a Motor

The following tables show feasible ways on how to connect the motor with its respective feedback signals or possible combinations thereof. To find the wiring that best suits your setup, proceed as follows:

- 1) Decide on the type of motor you are using; either DC or EC (BLDC or PMSM) motor.
- 2) Connect the power supply and the logic supply by following the link to the stated figure.
- 3) Check-out the listing for the combination that best suits your setup. Pick the wiring method # and go to the respective table; for DC motor → Table 4-63, for EC (BLDC or PMSM) motor → Table 4-64.
- 4) Pick the row with the corresponding wiring method # and follow the link (or links) to the stated figure(s) to find the relevant wiring information.

### 4.1.1 DC Motor 1...4

**Power supply & optional logic supply** ..... Figure 4-39

#### Motor & feedback signals

Without sensor ..... Method # DC1  
 Digital incremental encoder ..... Method # DC2  
 Analog incremental encoder SinCos ..... Method # DC3  
 SSI absolute encoder ..... Method # DC4

Method #	Digital Incremental Encoder 2 Xn2	Analog Incremental Encoder Xn2	SSI Absolute Encoder Xn2	→ Figure(s)
DC1				4-40
DC2	✓			4-40 4-43
DC3		✓		4-40 4-44
DC4			✓	4-40 4-45

Table 4-63 Possible combinations of feedback signals for DC motor

**4.1.2 EC (BLDC or PMSM) Motor 1...4**

**Power supply & optional logic supply** ..... Figure 4-39

**Motor & feedback signals**

Hall sensors ..... Method # EC1  
 Hall sensors & Digital incremental encoder ..... Method # EC2  
 Hall sensors & Analog incremental encoder SinCos ..... Method # EC3  
 Hall sensors & SSI absolute encoder ..... Method # EC4  
 Digital incremental encoder ..... Method # EC5  
 Analog incremental encoder SinCos ..... Method # EC6  
 SSI absolute encoder ..... Method # EC7

Method #	Hall sensors Xn1	Digital Incremental Encoder Xn2	Analog Incremental Encoder Xn2	SSI Absolute Encoder Xn2	➔ Figure(s)
EC1	✓				4-41 4-42
EC2	✓	✓			4-41 4-42 / 4-43
EC3	✓		✓		4-41 4-42 / 4-44
EC4	✓			✓	4-41 4-42 / 4-45
EC5		✓			4-41 4-43
EC6			✓		4-41 4-44
EC7				✓	4-41 4-45

Table 4-64 Possible combinations of feedback signals for EC (BLDC or PMSM) motor

## 4.2 Main Wiring Diagram



### Load capacity of the sensor supply

The maximum load of the sensor supply is 1 A for the total of all Hall sensors and encoders combined.

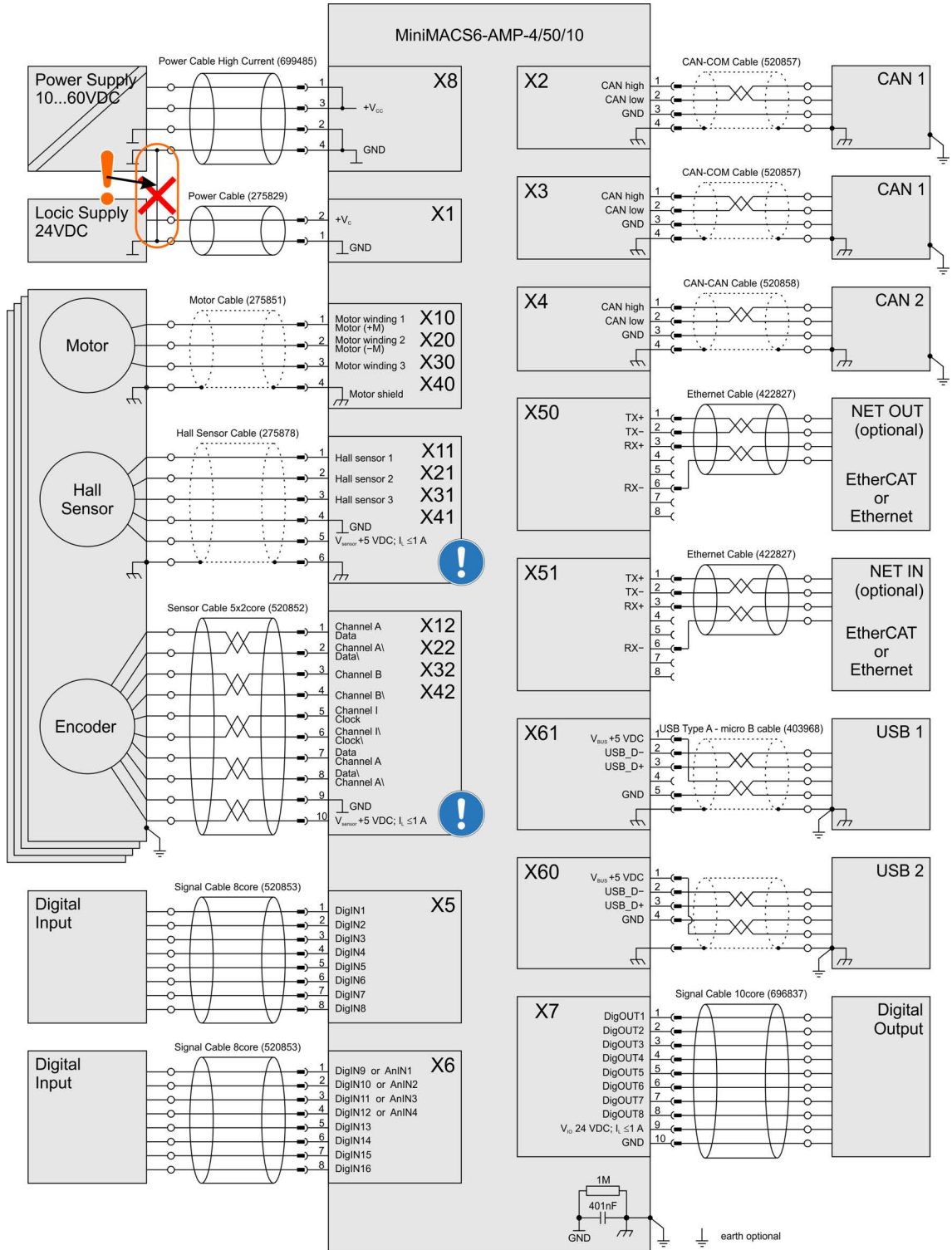

Figure 4-38 Main wiring diagram

### 4.3 Excerpts

#### 4.3.1 Power & Logic Supply



**Galvanic isolation**

The power supply must be electrically (galvanically) isolated from the logic supply.



**Grounding**

Wrong grounding can destroy the unit.

- Do not connect the power supply's ground (GND) to earth.
- Do not interconnect the power supply's ground (GND) with the logic supply's ground (GND).



**Connection of a switching element to the power supply**

Do not place any switching element in between the power supply and the connector X8. This will lead to massive inrush currents and might destroy the unit. If a power switch should be required, place it at the power supply's primary side.

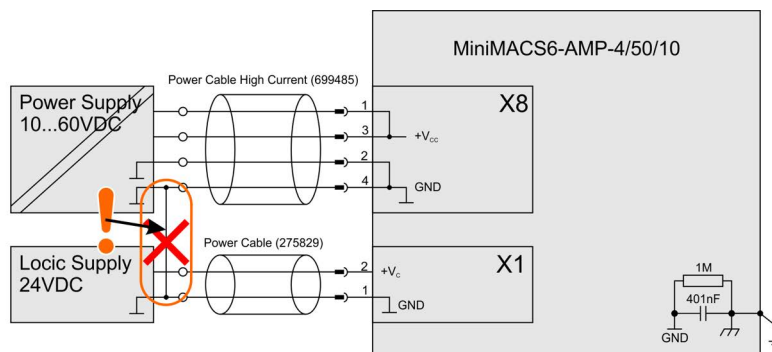

Figure 4-39 Power & logic supply

#### 4.3.2 DC Motor

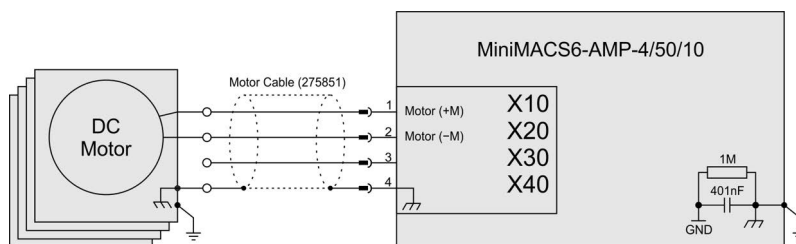

Figure 4-40 DC motor

### 4.3.3 EC (BLDC or PMSM) Motor

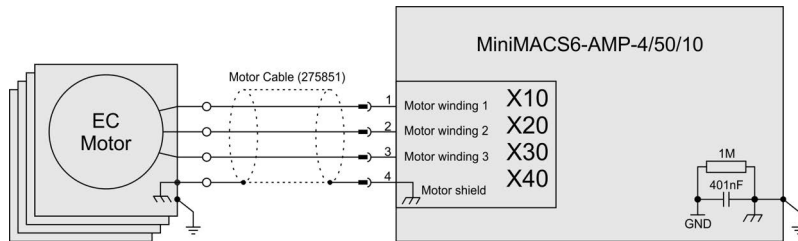

Figure 4-41 EC (BLDC, PMSM) motor

### 4.3.4 Hall Sensors

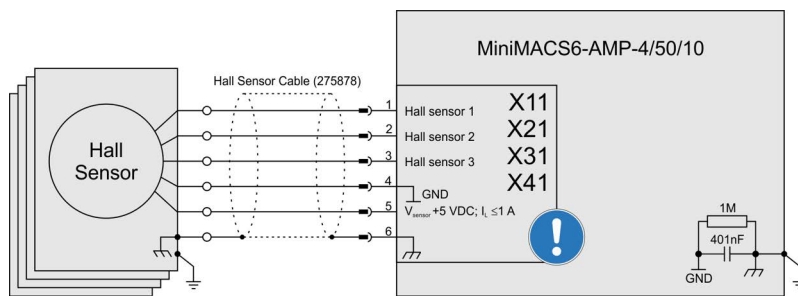

Figure 4-42 Hall sensors

### 4.3.5 Digital Incremental Encoder

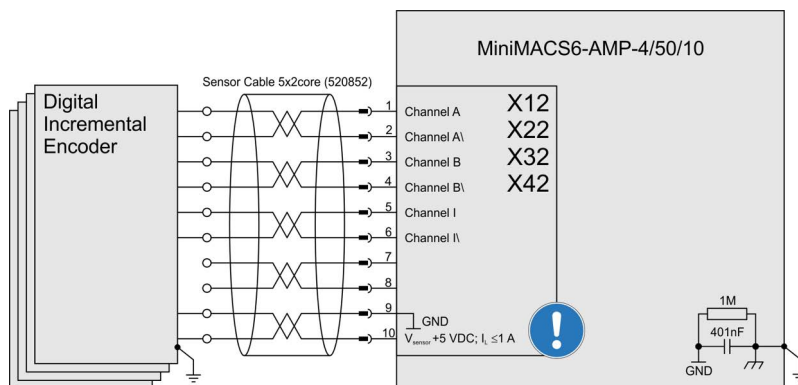

Figure 4-43 Digital incremental encoder

**4.3.6 Analog incremental encoder SinCos**

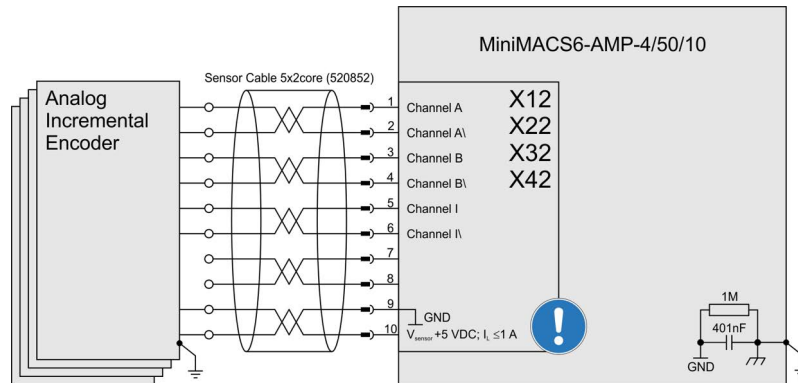

Figure 4-44 Analog incremental encoder SinCos

**4.3.7 SSI Encoder**

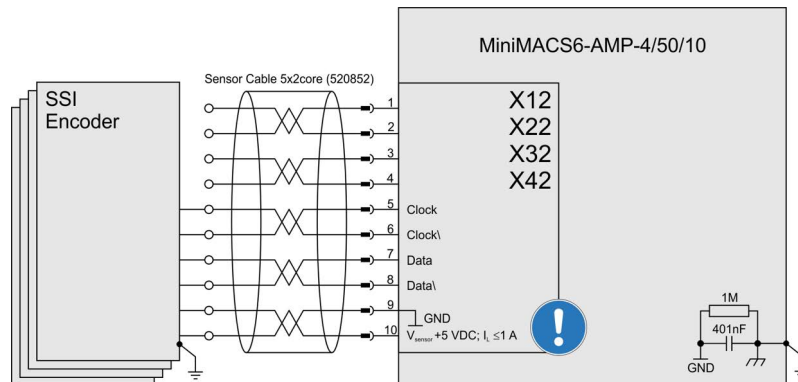

Figure 4-45 SSI encoder

••page intentionally left blank••



## LIST OF FIGURES

Figure 1-1	Documentation structure . . . . .	5
Figure 2-2	MiniMACS6-AMP-4/50/10 (001755) – Dimensional drawing [mm] . . . . .	14
Figure 2-3	MiniMACS6-AMP-4/50/10-IF1 EtherCAT (001757) and MiniMACS6-AMP-4/50/10-IF1 Ethernet (001784) – Dimensional drawing [mm]15	
Figure 2-4	MiniMACS6-AMP-4/50/10-OEM (001756) – Dimensional drawing [mm] . . . . .	16
Figure 3-5	Mounting holes . . . . .	21
Figure 3-6	Silicone pad . . . . .	22
Figure 3-7	Cooling plate . . . . .	22
Figure 3-8	Connectors . . . . .	25
Figure 3-9	Power supply connector X8 . . . . .	26
Figure 3-10	Logic supply connector X1 . . . . .	28
Figure 3-11	Motor connectors Xn0 . . . . .	29
Figure 3-12	Hall sensor connectors Xn1 . . . . .	36
Figure 3-13	Hall sensor 1 input circuit (analogously valid for Hall sensors 2 & 3 and other Xn1) . . . . .	37
Figure 3-14	Digital incremental master encoder input circuit Ch B is still an input identical to the è Digital Incremental Encoder . . . . .	38
Figure 3-15	Encoder connectors Xn2 . . . . .	39
Figure 3-16	Digital incremental encoder input circuit Ch A “differential” (analogously valid for Ch I and other Xn2) . . . . .	40
Figure 3-17	Digital incremental encoder input circuit Ch B “differential” (analogously valid for other Xn2) . . . . .	41
Figure 3-18	Digital incremental encoder input circuit Ch A “single-ended” (analogously valid for Ch B and other Xn2) . . . . .	42
Figure 3-19	Digital incremental encoder input circuit Ch I (analogously valid for other Xn2) . . . . .	43
Figure 3-20	Analog incremental encoder input circuit Ch A “differential” (analogously valid for Ch B and other Xn2) . . . . .	44
Figure 3-21	Analog incremental encoder input circuit Ch I (digital evaluation, analogously valid for other Xn2) . . . . .	45
Figure 3-22	SSI absolute encoder data input (analogously valid for other Xn2) . . . . .	46
Figure 3-23	SSI absolute encoder clock output (analogously valid for other Xn2) . . . . .	47
Figure 3-24	Glitch filter sequence diagram . . . . .	49
Figure 3-25	Digital input connectors X5, X6 . . . . .	50
Figure 3-26	DigIN1 circuit (analogously valid for DigIN2...16 and X6) . . . . .	51
Figure 3-27	AnIN1 circuit (analogously valid for AnIN2...4) . . . . .	51
Figure 3-28	Digital output connector X7 . . . . .	52
Figure 3-29	DigOUT1 circuit (analogously valid for DigOUT2...8) . . . . .	53
Figure 3-30	DigOUT1 “source” (analogously valid for DigOUT2...8) . . . . .	53
Figure 3-31	CAN 1 & CAN 2 connectors X2, X3, X4 . . . . .	54
Figure 3-32	USB 1 connector X61 . . . . .	56
Figure 3-33	USB 2 connector X60 . . . . .	57
Figure 3-34	NET OUT & NET IN connectors X50, X51 . . . . .	58
Figure 3-35	DIP switch SW1 . . . . .	60
Figure 3-36	LEDs – Location . . . . .	63
Figure 4-37	Interfaces – Designations and location . . . . .	65
Figure 4-38	Main wiring diagram . . . . .	68
Figure 4-39	Power & logic supply . . . . .	69
Figure 4-40	DC motor . . . . .	69

Figure 4-41	EC (BLDC, PMSM) motor . . . . .	70
Figure 4-42	Hall sensors . . . . .	70
Figure 4-43	Digital incremental encoder . . . . .	70
Figure 4-44	Analog incremental encoder SinCos . . . . .	71
Figure 4-45	SSI encoder . . . . .	71

## LIST OF TABLES

Table 1-1	Notation used	6
Table 1-2	Symbols and signs	6
Table 1-3	Brand names and trademark owners	7
Table 1-4	Available variants	8
Table 2-5	Technical data	13
Table 2-6	Limitations	13
Table 2-7	Standards	17
Table 3-8	Required parts for mechanical installation of PCB versions	21
Table 3-9	Prefab maxon cables	23
Table 3-10	MiniMACS6 AMP-4/50/10 Connector Set – Content	24
Table 3-11	Recommended tools	24
Table 3-12	Power supply connector X8 – Pin assignment	26
Table 3-13	Power Cable High Current	26
Table 3-14	Power supply requirements	27
Table 3-15	Logic supply connector X1 – Pin assignment	28
Table 3-16	Power Cable	28
Table 3-17	Power supply requirements	28
Table 3-18	Motor Cable	29
Table 3-19	Motor connectors Xn0 – Pin assignment for up to six DC motors	30
Table 3-20	Motor connectors Xn0 – Pin assignment for up to three DC twin motors	30
Table 3-21	Motor connectors Xn0 – Pin assignment for up to six brake choppers	31
Table 3-22	Motor connectors Xn0 – Pin assignment for up to four EC (BLDC, PMSM) motors	32
Table 3-23	Motor connectors Xn0 – Pin assignment for up to two EC (BLDC, PMSM) twin motors	32
Table 3-24	Motor connectors Xn0 – Pin assignment for up to three stepper motors	33
Table 3-25	Motor connectors Xn0 – Motor combination matrix	34
Table 3-26	Maximum duty cycle levels for different motor types and axis numbers	35
Table 3-27	Hall sensor connectors Xn1 – Pin assignment	36
Table 3-28	Hall Sensor Cable	36
Table 3-29	Hall sensor specification	37
Table 3-30	Differential digital incremental encoder specification	38
Table 3-31	Encoder connectors Xn2 – Pin assignment	39
Table 3-32	Sensor Cable 5x2core	39
Table 3-33	Differential digital incremental encoder specification	40
Table 3-34	Single-ended digital incremental encoder specification	42
Table 3-35	Differential analog incremental encoder specification	44
Table 3-36	SSI absolute encoder specification	46
Table 3-37	Parameter value diagram	48
Table 3-38	Parameter value diagram	48
Table 3-39	Digital input connector X5 – Pin assignment	50
Table 3-40	Digital input connector X6 – Pin assignment	50
Table 3-41	Signal Cable 8core	50

Table 3-42	Digital input specification . . . . .	51
Table 3-43	Analog input specification . . . . .	51
Table 3-44	Digital output connector X7 – Pin assignment . . . . .	52
Table 3-45	Signal Cable 10core . . . . .	52
Table 3-46	Digital output specification . . . . .	53
Table 3-47	Digital I/O output voltage specification . . . . .	53
Table 3-48	CAN 1 & CAN 2 connectors X2, X3, X4 – Pin assignment. . . . .	54
Table 3-49	CAN-COM Cable . . . . .	54
Table 3-50	CAN-CAN Cable. . . . .	55
Table 3-51	CAN interface specification . . . . .	55
Table 3-52	USB 1 connector X61 – Pin assignment . . . . .	56
Table 3-53	USB 1 Type A - micro B Cable . . . . .	56
Table 3-54	USB interface specification. . . . .	56
Table 3-55	USB 2 connector X60 – Pin assignment . . . . .	57
Table 3-56	NET OUT & NET IN connectors X50, X51 – Pin assignment. . . . .	58
Table 3-57	Ethernet Cable . . . . .	59
Table 3-58	DIP switch SW1 – Binary code values . . . . .	61
Table 3-59	DIP switch SW1 – Examples . . . . .	61
Table 3-60	DIP switch SW1 – CAN bus termination. . . . .	62
Table 3-61	EtherCAT mode – LEDs . . . . .	64
Table 3-62	Ethernet mode – LEDs . . . . .	64
Table 4-63	Possible combinations of feedback signals for DC motor . . . . .	66
Table 4-64	Possible combinations of feedback signals for EC (BLDC or PMSM) motor . . . . .	67

## INDEX

### A

alerts 6  
 analog incremental encoder (differential) 44  
 analog inputs 51  
 applicable EU directive 19  
 applicable regulations 9

### B

Beckhoff TwinCAT 8  
 BiSS encoder, wiring 71  
 bit rate, default 55  
 BLDC motors, connection of 31

### C

cables (prefab)  
   CAN-CAN Cable 55  
   CAN-COM Cable 54  
   Ethernet Cable 59  
   Hall Sensor Cable 36  
   Motor Cable 29  
   Power Cable 28  
   Power Cable High Current 26  
   Sensor Cable 5x2core 39  
   Signal Cable 10core 52  
   Signal Cable 8core 50  
   USB Type A - micro B Cable 56

CAN bus termination 55, 62

CAN ID (see "ID")

CAN interface 55

combination matrix 34

connectors

  X1 28  
   X10, X20, X30, X40 29  
   X11, X21, X31, X41 36  
   X12, X22, X32, X42 38  
   X2 54  
   X3 54  
   X4 54  
   X5, X6 50  
   X50 58  
   X51 58  
   X61 56, 57  
   X7 52  
   X8 26

cooling of PCB versions 20

country-specific regulations 9

### D

DC motors, connection of 30  
 DEV ID (see "ID")  
 device condition, display of 63  
 digital incremental encoder (differential) 38, 40  
 digital incremental encoder (single-ended) 42  
 digital inputs 51  
 digital outputs 53  
 DIP switch SW1 60

### E

earthing of PCB versions 20  
 EC motors, connection of 31  
 encoders  
   absolute 46  
   incremental 38, 40  
   serial 46  
   SinCos 44  
 EnDat encoder, wiring 71  
 ESD 9  
 EtherCAT  
   extension card 8  
   network 8  
 Ethernet switch 59  
 EU directive, applicable 19  
 external memory 57

### H

Hall sensor 37  
 heat dissipation of PCB versions 20  
 how to  
   calculate the required supply voltage 27  
   interpret icons (and signs) used in this document 6

### I

ID (of the device) 61  
 IF1 (extension card) 8  
 incorporation into surrounding system 19  
 informatory signs 6  
 inputs  
   analog 51  
   digital 51  
 interfaces  
   CAN 54  
   EtherCAT 58  
   Ethernet 58  
   location and designation 25, 65  
   USB 56, 57

### L

LEDs, interpretation of 63

### M

mandatory action signs 6  
 memory stick 57  
 memory, external 57  
 MiniMACS6 AMP-4/50/10 Connector Set 23  
 motor combination matrix 34  
 motor types, supported 8

### N

node address (see "ID")  
 Node-ID (see "ID")  
 notations used 6

### O

operating license 19

outputs, digital 53

## P

part numbers

001755 8  
001756 8  
001757 8  
001772 23  
001784 8  
275829 28  
275851 29  
275878 36  
403968 56  
422827 59  
520852 39  
520853 50  
520857 54  
520858 55  
696837 52  
699485 26

performance data 11

PMSM motors, connection of 31

power supply requirements 27, 28

precautions 9

prerequisites prior installation 19

prohibitive signs 6

protective measures (ESD) 9

purpose

of the device 8

of the document 5

## R

recommended tools 24

regulations, applicable 9

requirements of power supply 27, 28

## S

safety alerts 6

signs used 6

SSI encoder

specification 46

wiring 71

standards, fulfilled 17

status LEDs 63

stepper motors, connection of 32

supply voltage, required 27

SW1 60

symbols used 6

## T

technical data 11

termination (CAN bus) 55, 62

tools, recommended 24

TwinCAT 8

## U

USB port 56, 57

USB stick 57

## W

wiring examples

analog incremental encoder 71

DC motor 69

digital incremental encoder 70

EC (BLDC) motor 70

Hall sensors 70

logic supply 69

power supply 69

SSI encoder 71





EtherCAT® is a registered trademark and patented technology, licensed by Beckhoff Automation GmbH, Germany

© 2023 maxon. All rights reserved. Any use, in particular reproduction, editing, translation and copying without prior written approval is not permitted (contact: maxon international ltd., Brünigstrasse 220, CH-6072 Sachseln, +41 41 666 15 00, [www.maxongroup.com](http://www.maxongroup.com)). Infringements will be prosecuted under civil and criminal law. The mentioned trademarks belong to their respective owner and are protected under trademark laws. Subject to change without prior notice.